Event Processing as a Service

Bob Marcus
bobmarcus1@comcast.net

Cloud Computing

Cloud Definition

- **Cloud Computing (from Gartner Group)** = *“a style of computing where massively scalable IT-enabled capabilities are delivered 'as a service' to external customers using Internet technologies” ... The key activity will be to determine which cloud services will be viable, and when.*

Service Oriented Levels

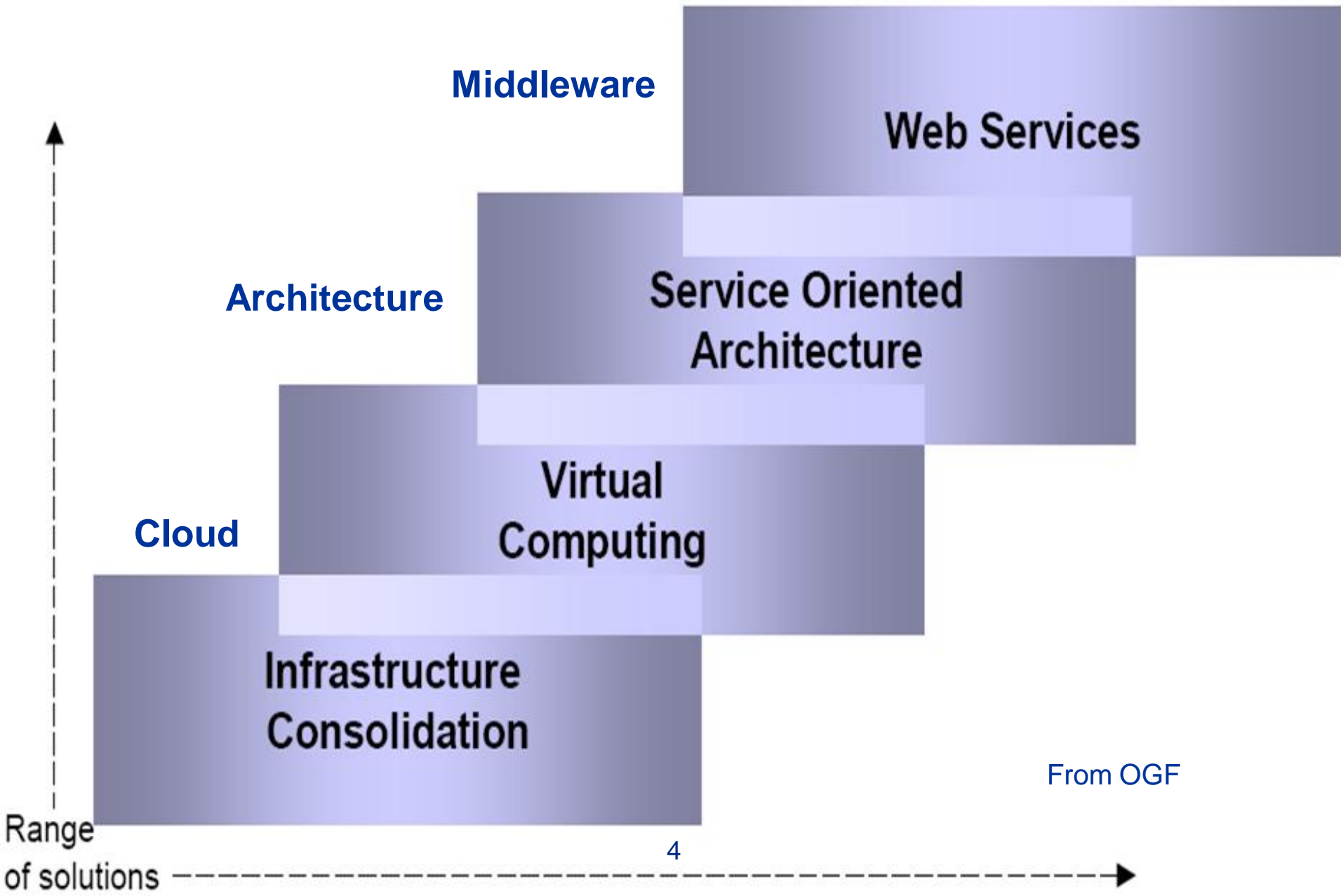

Cloud Computing Services Layers

Event, Processes, Interfaces (e.g. Event Processing as a Service)

Application Services (e.g. Software as a Service = SaaS)

Middleware and Data Services (e.g. Database as a Service)

Development and Deployment Services (e.g. Platform as a Service)

Resource Services (e.g. Infrastructure as a Service)

Distributed Virtualization Services

Computing Hardware and Physical Storage

Service-based Cloud Computing Architecture

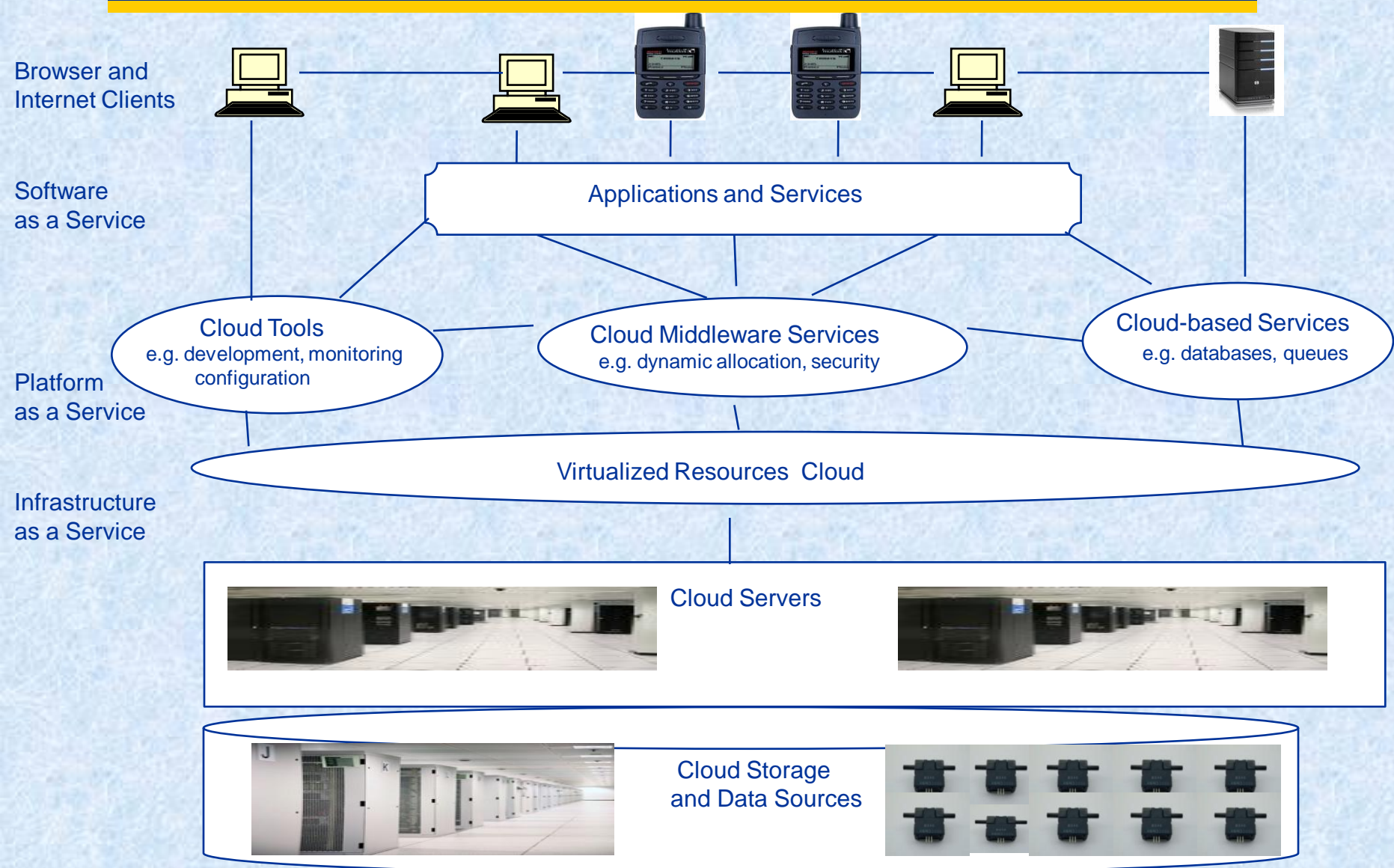

Enterprise Cloud Computing Group

- An Enterprise Cloud Computing Group was initiated September 17 at an NCOIC.org meeting including industry, government, standards groups, and vendors
- The goal of the Group will be to exchange information about standardizations, critical requirements, best practices, methodologies, success stories, and emerging technologies
- There is a planned follow-on meeting at an Open Group Conference in San Diego, February 2-5, 2009

Event Processing

Event Processing as a Service

- Complex event processing (CEP) is a key component for many application areas (e.g. finance, supply chain, intelligence, counter-terrorism, situation awareness)
- Required resources for CEP may fluctuate greatly over time (e.g. emergency response)
- Deploying “Event Processing as a Service” on a Cloud infrastructure could support dynamic requirements
- “Event Processing as Service” needs standardizations:
 - Describe event patterns of interest
 - Specify quality of services for reporting events
 - Identifying event sources to be monitored

Event Processing Using Multiple Services

- Remote Monitoring as a Service
 - Selection of sensing source and data feeds to monitor
 - Ability to turn on sensing sources or data feeds
- QoS as a Service
 - Event transmission and processing as a Service using priorities
 - Middleware support (e.g. OMG Data Distribution Services)
 - Network and compute resources to be applied
- Pattern Detection (CEP)
 - Computing as a Service to obtain resources
 - Software as a Service to utilize specific applications (e.g. CEP)

Information Networking Platform

Select Sources

Select Priorities

Select Patterns

Event Processing as a Service (My inserts)

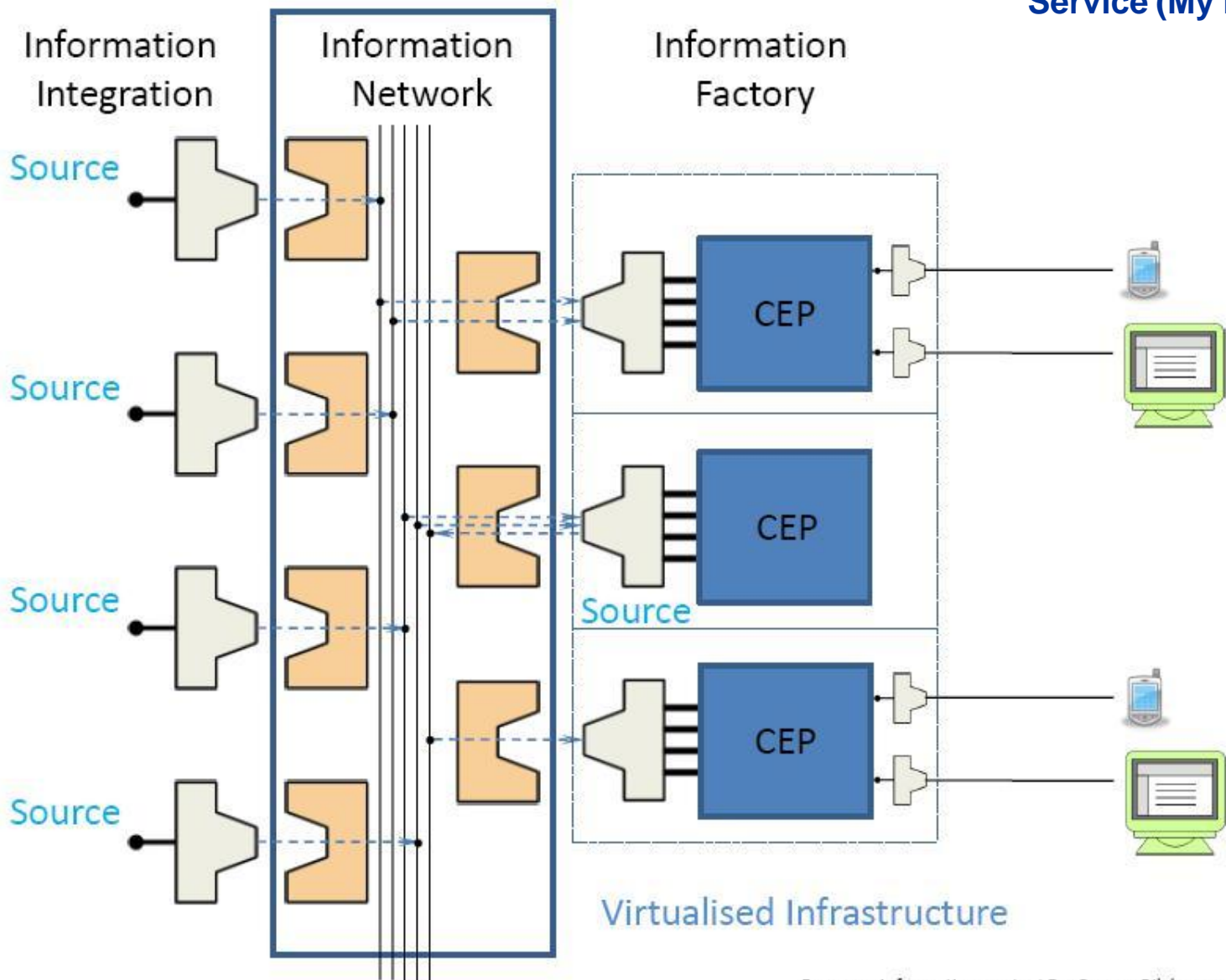

Map Reduce(Complex Event Processing)

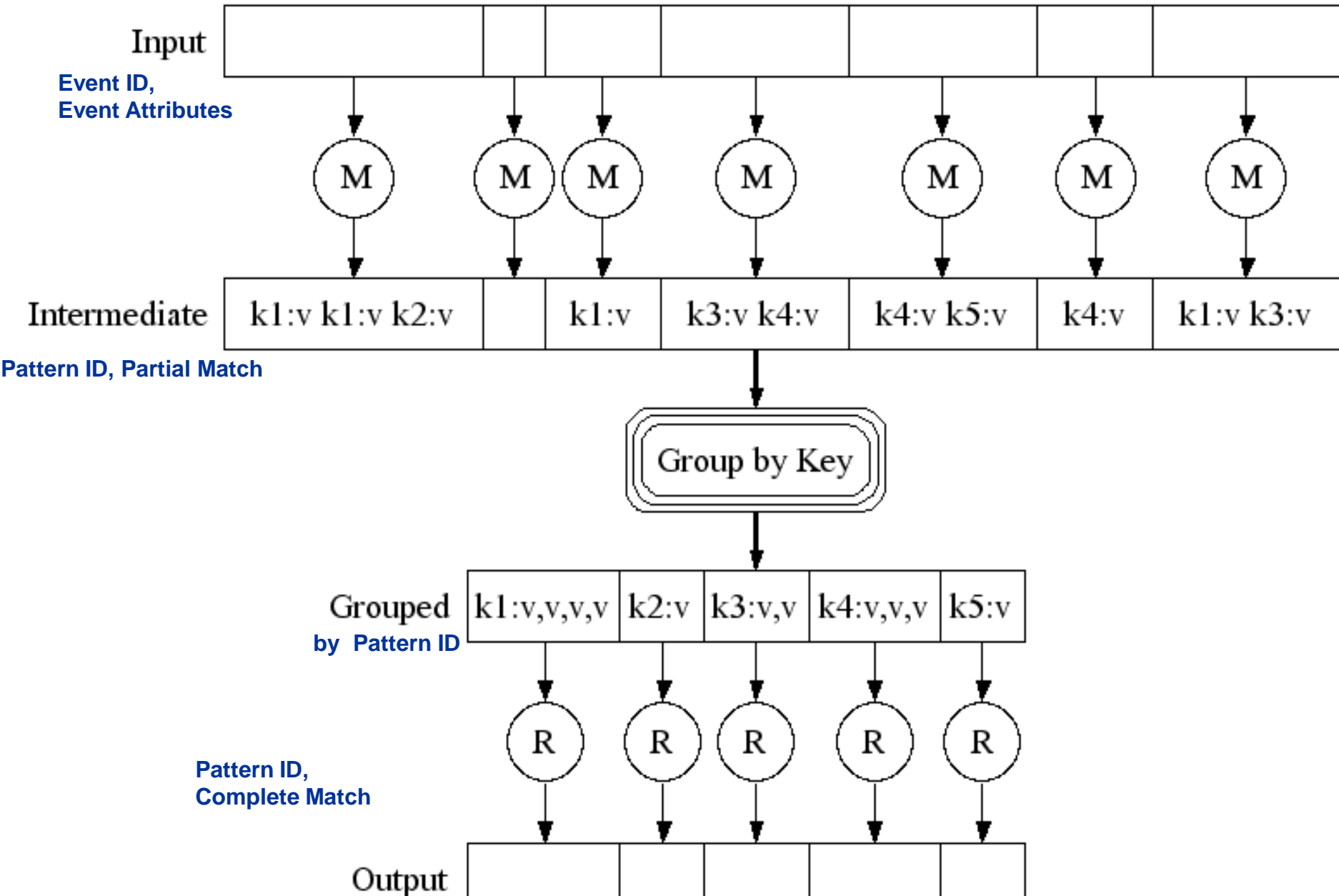

Monitoring Data Sources as a Service

- **Monitoring as a Service** - is the provision of monitoring (e.g. network monitoring, website monitoring, backup, security, and compliance monitoring) as a service
- **Monitoring as a service** providers include:
 - Redhat Command Center (Enterprise Systems)
 - Hyperic CloudStatus (Amazon Web Services, Google App Engine)
 - TrustSaaS (SaaS alerting and reporting)
 - Just Uptime (Web site monitoring)
- **Some Other Large Scale Sensing Projects**
 - Intel IrisNet (Internet-scale Resource-Intensive Sensor Network Service)
 - Microsoft SenseWeb
 - Sensor Web from GEOSS (Global Earth Observation System of Systems)

QoS as a Service

Future: Messaging Switch (e.g. Tervela)

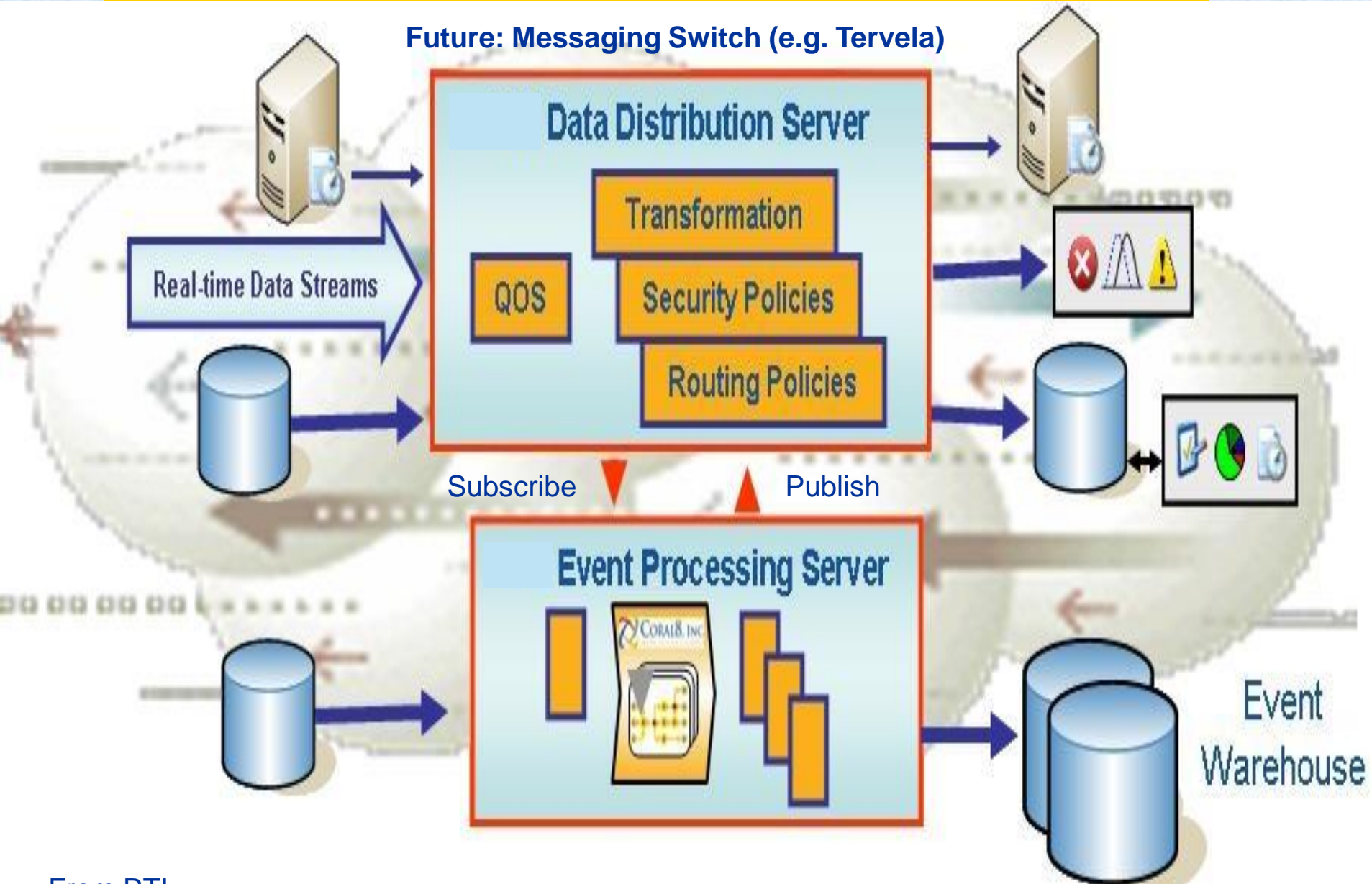

QoS Policies Supported by OMG DDS

- Data-Centric Publish-Subscribe entities (e.g., topics, data readers/writers) configurable via QoS policies
- QoS tailored to data distribution in tactical information systems
 - *DEADLINE*
 - Establishes contract regarding rate at which periodic data is refreshed
 - *LATENCY_BUDGET*
 - Establishes guidelines for acceptable end-to-end delays
 - *TIME_BASED_FILTER*
 - Mediates exchanges between slow consumers & fast producers
 - *RESOURCE_LIMITS*
 - Controls resources utilized by service
 - *RELIABILITY (BEST_EFFORT, RELIABLE)*
 - Enables use of real-time transports for data
 - *HISTORY (KEEP_LAST, KEEP_ALL)*
 - Controls which (of multiple) data values are delivered
 - *DURABILITY (VOLATILE, TRANSIENT, PERSISTENT)*
 - Determines if data outlives time when they are written
 - ...

CEP as a Service (Description Language)

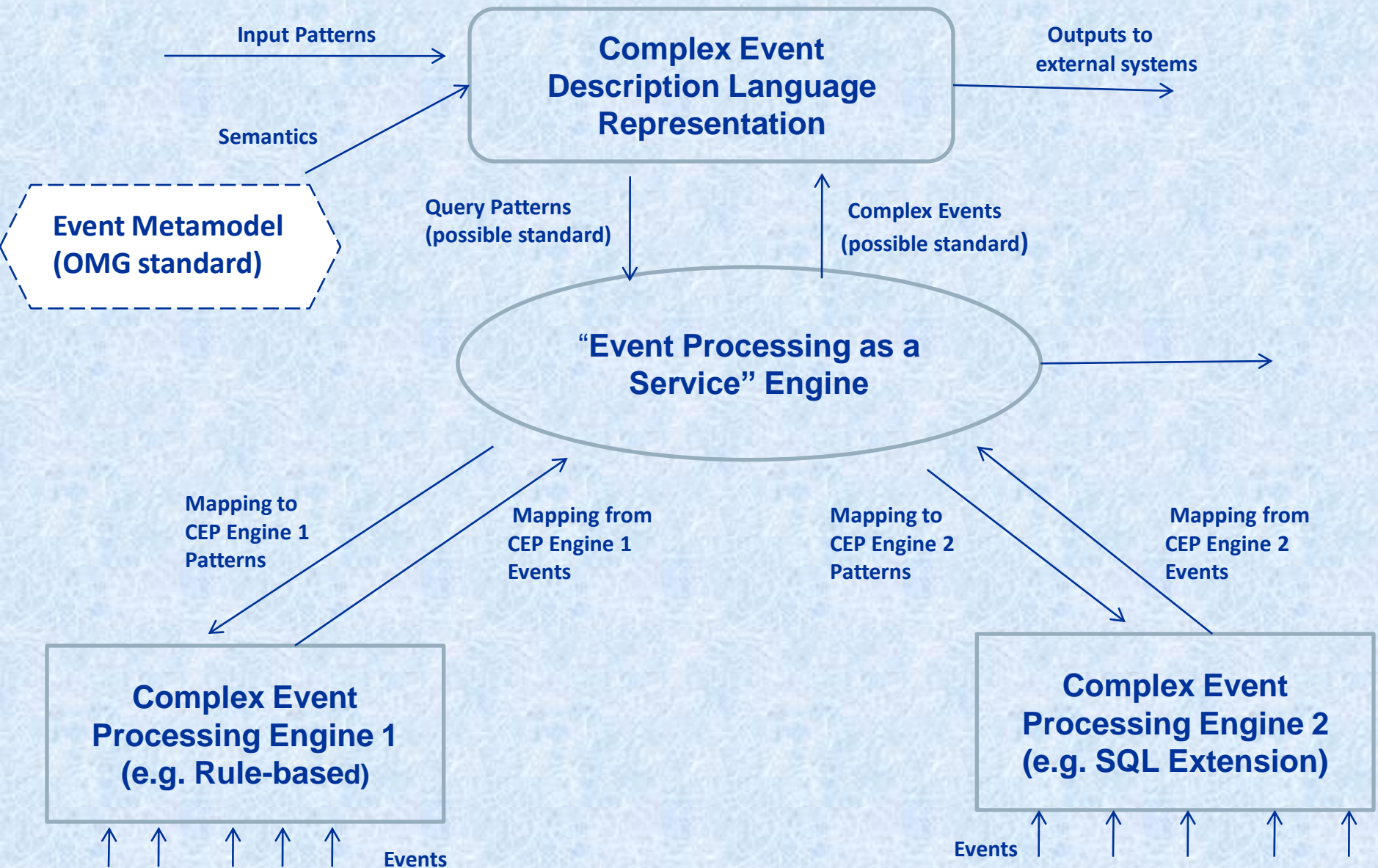

Final Predictions

- In the next decade, there will be multiple Cloud Event Processing Services (individual, enterprise)
- This will be a necessity for filtering the deluge of information that will flood current resources
- These Services will input data sources, desired level of service, and prioritized patterns of interest
- Output will be produced and delivered in an easy-to-use structured format
- Data collected from the Event Processing Services will provide the base for future advances
e.g. <http://googleblog.blogspot.com/2008/09/intelligent-cloud.html>

END