

Analysis of Feedback Control Systems

Introduction to Feedback Control Systems	1
Closed Loop Response.....	2
Breaking Apart the Problem to Calculate the Overall Transfer Function	4
Shortcuts for Calculating Overall Transfer Functions.....	5
Inner Feedback Loop Example.....	5
Feedforward Example	6
Internal Feedforward Example	7
Developing Block Diagram from Process Equations	8
Typical controller strategies.....	10
Effect of Controller Strategies on First Order Process.....	12
Effect of Proportional Control	12
Effect of PI Control.....	15
Effect of PID Control.....	18

Introduction to Feedback Control Systems

Block diagram of generalized process & corresponding feedback control loop.

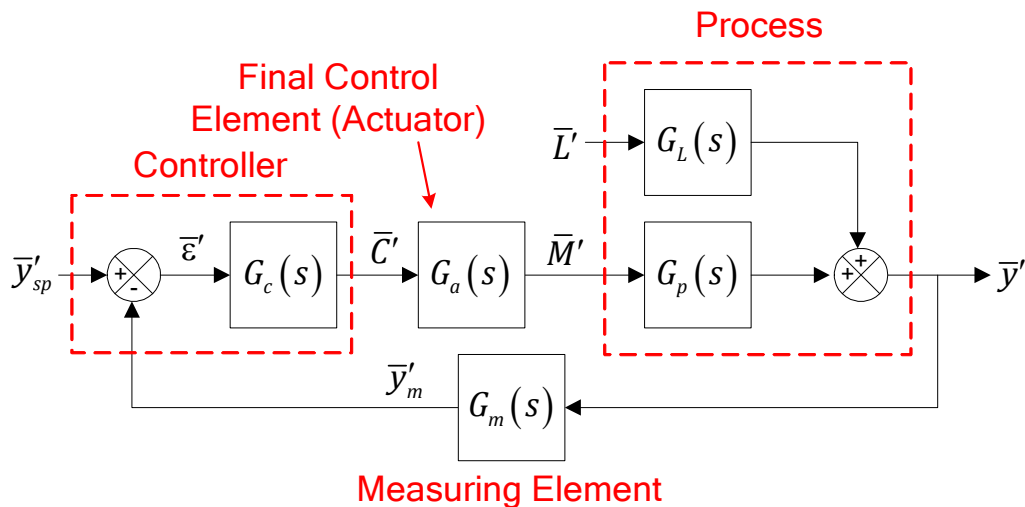

The process has 2 inputs, the disturbance L (also known as the *load* or the *process load*) and a measurable variable M , and one output y (the *controlled variable*). The disturbance L changes unpredictably. Our goal is to adjust the measurable variable M so that we keep the output variable y as steady as possible. Feedback control takes the following steps:

- Measure the value of the output, y_m .
- Compare y_m to the set point, y_{sp} . Determine the deviation $\varepsilon = y_{sp} - y_m$.

- Deviation processed by controller to give an output signal C to the final control element. The final control element makes change to the measurable control variable M .

The process itself is referred to as *open loop* as opposed to when the control is turned on when it is referred to as *closed loop*.

Types of feedback control systems:

- FC — flow control
- PC — pressure control
- LC — liquid-level control
- TC — temperature control
- CC — composition control

Typical measuring devices:

- Temperature: thermocouples
- Pressure: pressure transducers
- Flow: orifice plates, venturi tubes, turbine flow meters, hot-wire anemometers
- Liquid-level: float-actuated devices
- Composition: chromatographs, IR analyzers, UV analyzers, pH meters

Final control elements are typically valves of some sort. Depending upon situation, specified as *fail open* or *fail close*.

Closed Loop Response

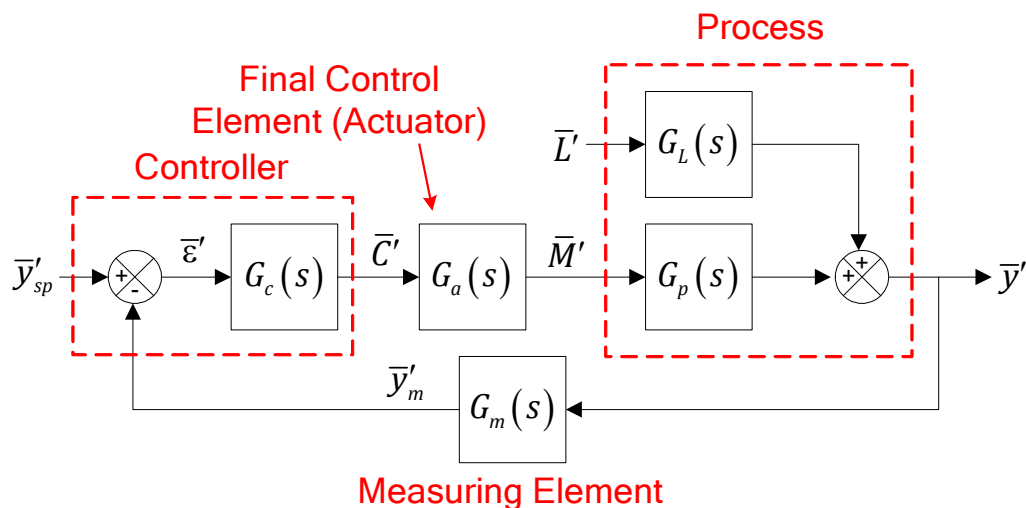

Above is a block diagram for a generalized closed-loop system. We have equations for:

$$\begin{aligned}
\text{Process:} & \quad \bar{y}' = G_p \bar{M}' + G_L \bar{L}' \\
\text{Measuring Element:} & \quad \bar{y}'_m = G_m \bar{y}' \\
\text{Comparator:} & \quad \bar{\varepsilon}' = \bar{y}'_{sp} - \bar{y}'_m \\
\text{Controller Output:} & \quad \bar{C}' = G_c \bar{\varepsilon}' \\
\text{Final Control Element:} & \quad \bar{M}' = G_a \bar{C}'
\end{aligned}$$

We would like a set of transfer functions that relate the output \bar{y}' to the two inputs \bar{y}'_{sp} & \bar{L}' (which is the overall box around the process & feedback control loop). The transfer functions should have the form:

$$\bar{y}' = G_{\text{SetPoint}} \cdot \bar{y}'_{sp} + G_{\text{Load}} \cdot \bar{L}' .$$

We have individual transfer functions that will make up these overall transfer functions. We just have to combine them using standard rules of algebra. Starting with the equation for the final control element:

$$\bar{M}' = G_a \bar{C}'$$

$$\bar{M}' = G_a (G_c \bar{\varepsilon}') \quad \text{Insert equation for controller output}$$

$$\bar{M}' = G_a G_c (\bar{y}'_{sp} - \bar{y}'_m) \quad \text{Insert equation for comparator}$$

$$\bar{M}' = G_a G_c (\bar{y}'_{sp} - G_m \bar{y}') \quad \text{Insert equation for measuring device}$$

and then insert this into the process equation:

$$\bar{y}' = G_p G_a G_c (\bar{y}'_{sp} - G_m \bar{y}') + G_L \bar{L}' .$$

Algebraically solving for \bar{y}' :

$$\bar{y}' = G_p G_a G_c \bar{y}'_{sp} - G_m G_p G_a G_c \bar{y}' + G_L \bar{L}' .$$

$$(1 + G_m G_p G_a G_c) \bar{y}' = G_p G_a G_c \bar{y}'_{sp} + G_L \bar{L}' .$$

$$\bar{y}' = \frac{G_p G_a G_c}{1 + G_m G_p G_a G_c} \bar{y}'_{sp} + \frac{G_L}{1 + G_m G_p G_a G_c} \bar{L}' .$$

so: $G_{\text{SetPoint}} = \frac{G_p G_a G_c}{1 + G_m G_p G_a G_c}$ and $G_{\text{Load}} = \frac{G_L}{1 + G_m G_p G_a G_c}$.

Usually look at two types of problems:

- *Servo problem.* No disturbance & controller acts to keep the output near the set point:

$$\bar{y}' = G_{\text{SetPoint}} \cdot \bar{y}'_{sp}$$

- *Regulator problem.* Set point remains the same & controller acts to smooth out disturbances:

$$\bar{y}' = G_{\text{Load}} \cdot \bar{L}'$$

Breaking Apart the Problem to Calculate the Overall Transfer Function

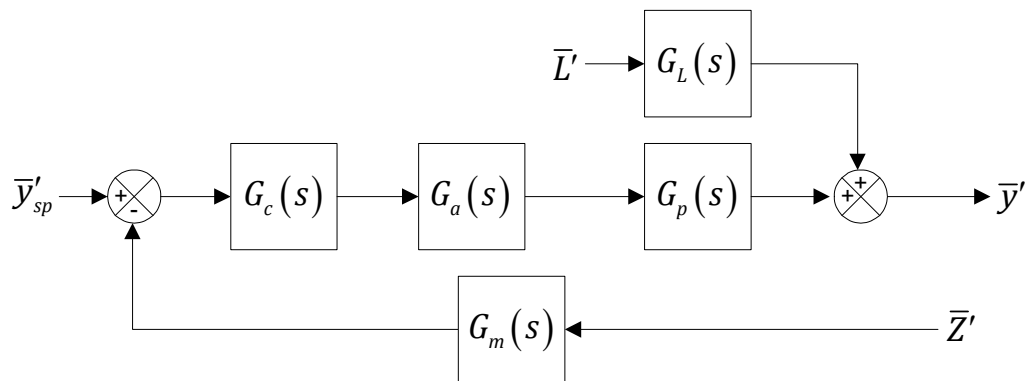

This is a lot of math. We can get the same thing by starting with a problem where there are THREE inputs and everything feeds in a forward direction. Consider the block flow diagram above. The relationship between the three inputs is:

$$\bar{y}' = [G_p G_a G_c] \bar{y}'_{sp} + [G_L] \bar{L}' - [G_m G_p G_a G_c] \bar{Z}'$$

However, note that this block diagram is simply the first one we looked at with $\bar{Z}' = \bar{y}'$. So we can make this substitution & do a bit of algebra to get:

$$\bar{y}' = [G_p G_a G_c] \bar{y}'_{sp} + [G_L] \bar{L}' - [G_m G_p G_a G_c] \bar{y}'$$

$$[1 + G_m G_p G_a G_c] \bar{y}' = [G_p G_a G_c] \bar{y}'_{sp} + [G_L] \bar{L}'$$

$$\bar{y}' = \frac{G_p G_a G_c}{1 + G_m G_p G_a G_c} \bar{y}'_{sp} + \frac{G_L}{1 + G_m G_p G_a G_c} \bar{L}'$$

which is what we determined before.

Shortcuts for Calculating Overall Transfer Functions

Evaluating the overall transfer function between an input & output can get quite complicated, especially if there are several loads and loops. For a system with a single feedback loop, the transfer function between an input \bar{Y}'_{in} and an output \bar{Y}'_{out} is:

$$\frac{\bar{Y}'_{out}}{\bar{Y}'_{in}} = \frac{(-1)^{n_f} \Pi_f}{1 - (-1)^{n_\ell} \Pi_\ell}$$

where Π_f is the product of the transfer functions between \bar{Y}'_{in} and \bar{Y}'_{out} , Π_ℓ is the product of all transfer functions within the loop, and n_f and n_ℓ are then number of negative signs within the forward path & the loop, respectively. For a simple feedback control loop which only has a negative sign in the comparator the loop law is:

$$\frac{\bar{Y}'_{out}}{\bar{Y}'_{in}} = \frac{\Pi_f}{1 + \Pi_\ell}$$

If there are multiple loops, then the situation gets more complicated. If the loops are all embedded and do not cross boundaries then this loop formula can be applied sequentially.

Inner Feedback Loop Example

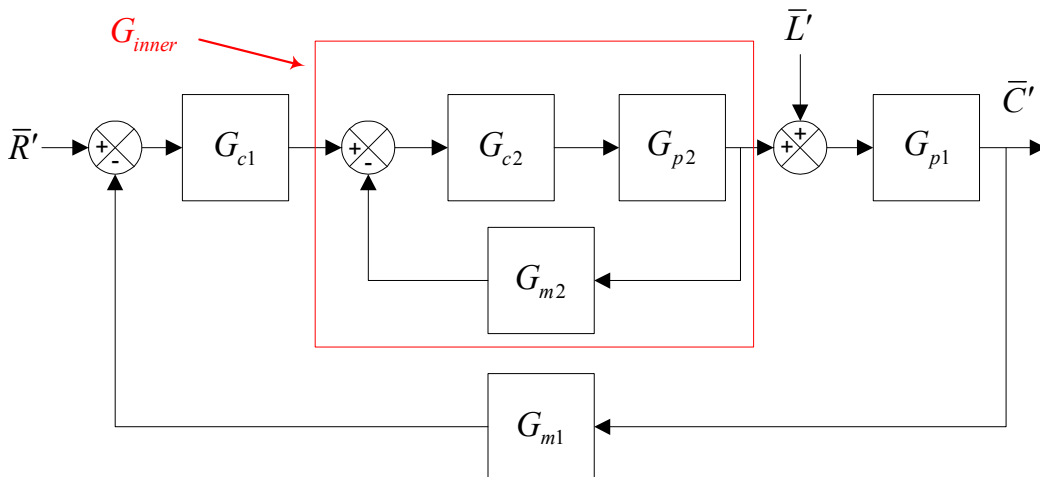

This block diagram is an embedded, multi-loop example (i.e., cascade control). To get the transfer function between \bar{R}' and \bar{C}' we must first replace the inner loop with an overall transfer function & then can take care of the outer loop. The inner loop transfer function will be:

$$\frac{\bar{Y}_{out}}{\bar{Y}_{in}} = G_{inner} = \frac{\Pi_f}{1 + \Pi_\ell} = \frac{G_{c2}G_{p2}}{1 + G_{c2}G_{p2}G_{m2}}$$

Now, the overall transfer function will be:

$$\frac{\bar{C}'}{\bar{R}'} = \frac{\Pi_f}{1 + \Pi_\ell} = \frac{G_{c1}G_{inner}G_{p1}}{1 + G_{c1}G_{inner}G_{p1}G_{m1}} = \frac{G_{c1} \frac{G_{c2}G_{p2}}{1 + G_{c2}G_{p2}G_{m2}} G_{p1}}{1 + G_{c1} \frac{G_{c2}G_{p2}}{1 + G_{c2}G_{p2}G_{m2}} G_{p1}G_{m1}}$$

$$\frac{\bar{C}'}{\bar{R}'} = \frac{G_{c1}G_{c2}G_{p2}G_{p1}}{1 + G_{c2}G_{p2}G_{m2} + G_{c1}G_{c2}G_{p2}G_{p1}G_{m1}}$$

Feedforward Example

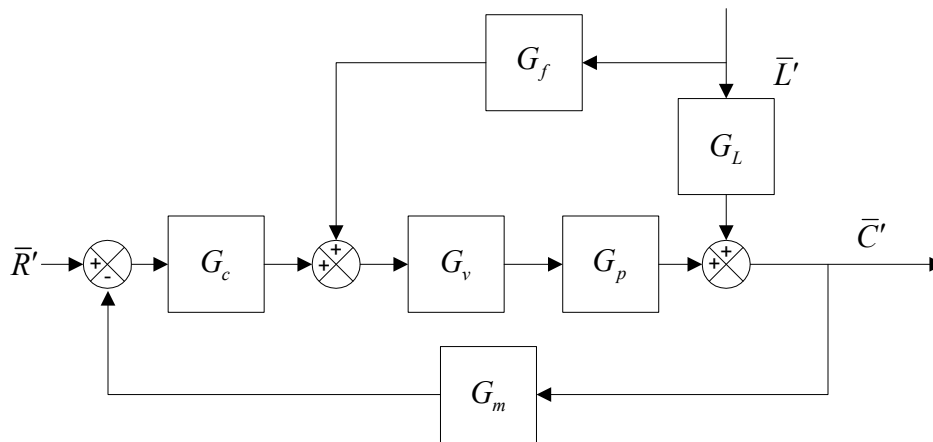

This block diagram is for a situation where the load information is combined with the output information to give a combined feedforward-feedback control. To get the transfer function between \bar{L}' and \bar{C}' we must consider both forward paths. The output \bar{C}' for the two separate paths involving \bar{L}' will give:

$$\bar{C}' = \frac{G_L}{1 + G_m G_c G_v G_p} \bar{L}' + \frac{G_f G_v G_p}{1 + G_m G_c G_v G_p} \bar{L}'.$$

Now, the overall transfer function will be:

$$\frac{\bar{C}'}{\bar{L}'} = \frac{G_L + G_f G_v G_p}{1 + G_m G_c G_v G_p}$$

Internal Feedforward Example

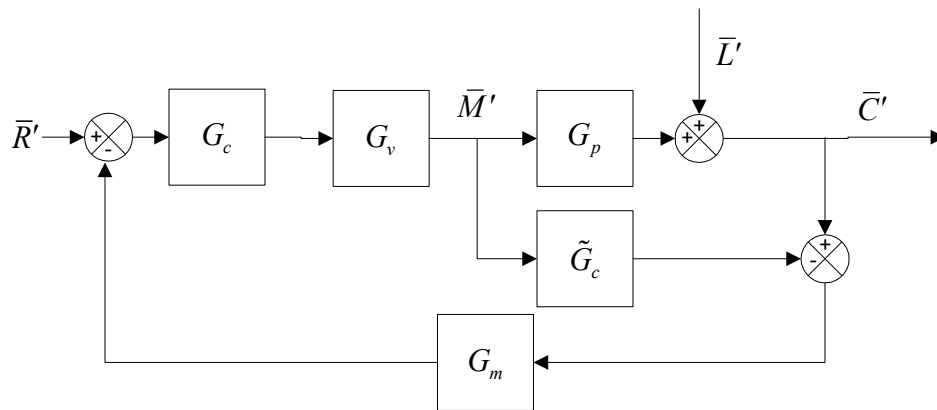

This block diagram is for a situation where the information for the manipulated variable goes through an internal model. (See Chapter 12.) Now there are two feedback loops. We can split off one with the following block diagram. We've added a new input (well, kind of, since we really know that $\bar{Z}' = \bar{C}'$) but we only have one feedback loop.

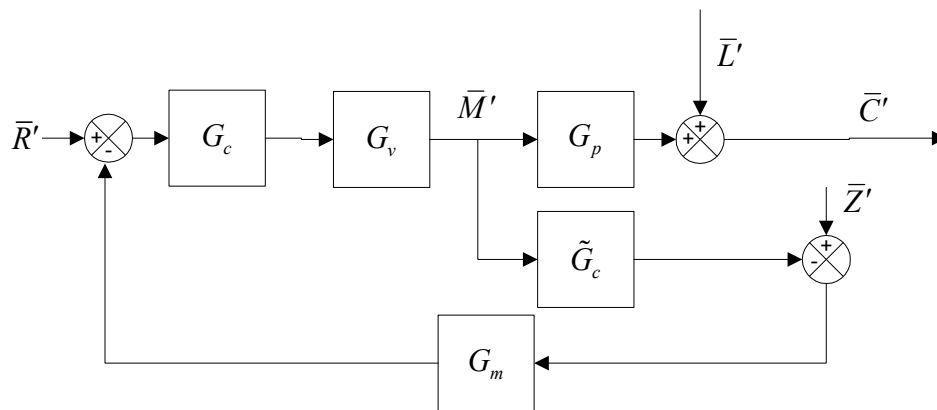

The relationship of the output (\bar{C}') to each of the inputs will be:

$$\bar{C}' = \bar{L}' + \frac{G_c G_v G_p}{1 - G_c G_v \tilde{G}_c G_m} \cdot \bar{R}' - \frac{G_m G_c G_v G_p}{1 - G_c G_v \tilde{G}_c G_m} \cdot \bar{Z}'$$

(Note that \bar{L}' is not part of the feedback loop!)

$$\left[1 - G_c G_v \tilde{G}_c G_m\right] \bar{C}' = \left[1 - G_c G_v \tilde{G}_c G_m\right] \bar{L}' + \left[G_c G_v G_p\right] \bar{R}' - \left[G_m G_c G_v G_p\right] \bar{Z}'$$

Now we take into account that $\bar{Z}' = \bar{C}'$:

$$\left[1 - G_c G_v \tilde{G}_c G_m\right] \bar{C}' = \left[1 - G_c G_v \tilde{G}_c G_m\right] \bar{L}' + \left[G_c G_v G_p\right] \bar{R}' - \left[G_m G_c G_v G_p\right] \bar{C}'$$

$$\left[1 + G_m G_c G_v G_p - G_c G_v \tilde{G}_c G_m\right] \bar{C}' = \left[1 - G_c G_v \tilde{G}_c G_m\right] \bar{L}' + \left[G_c G_v G_p\right] \bar{R}'$$

$$\left[1 + G_m G_v G_p (G_c - \tilde{G}_c)\right] \bar{C}' = \left[1 - G_c G_v \tilde{G}_c G_m\right] \bar{L}' + \left[G_c G_v G_p\right] \bar{R}'$$

$$\bar{C}' = \frac{1 - G_c G_v \tilde{G}_c G_m}{1 + G_m G_v G_p (G_c - \tilde{G}_c)} \bar{L}' + \frac{G_c G_v G_p}{1 + G_m G_v G_p (G_c - \tilde{G}_c)} \bar{R}'$$

So, the overall transfer functions are:

$$G_{load} = \frac{\bar{C}'}{\bar{L}'} = \frac{1 - G_c G_v \tilde{G}_c G_m}{1 + G_m G_v G_p (G_c - \tilde{G}_c)}$$

$$G_{sp} = \frac{\bar{C}'}{\bar{R}'} = \frac{G_c G_v G_p}{1 + G_m G_v G_p (G_c - \tilde{G}_c)}$$

Developing Block Diagram from Process Equations

Let's draw a block diagram for level control on a single tank. As the manipulated variable we can use either the effluent flow rate, F_1 , or in the inlet flow rate, F_0 . When F_0 is the manipulated (i.e., control) variable then let's use $F_1 = C_1 h_1$. The overall material balance becomes:

$$A \frac{dh'}{dt} = F_0' - C_1 h' \Rightarrow \bar{h}' = \frac{\frac{1}{C_1}}{\frac{A}{C_1} s + 1} \bar{F}_0' = \frac{K_p}{\tau_p s + 1} \bar{F}_0'$$

The process itself looks like the following.

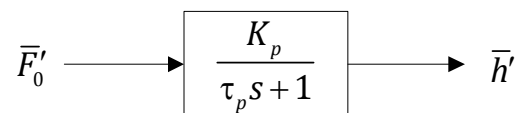

If we measure the liquid level & control its value with the inlet flowrate then process looks like the following. Note that there is a manipulated variable but no load:

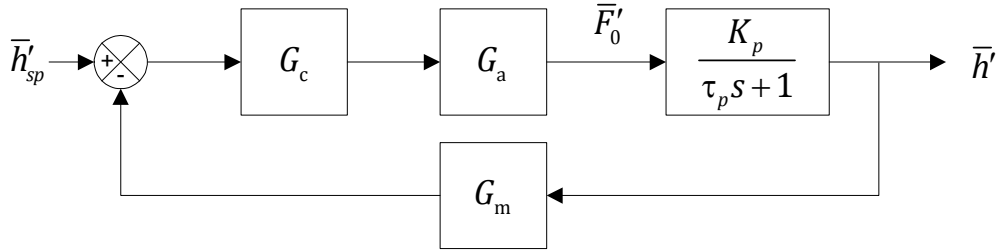

Let's control the liquid level by manipulating the outlet flow (such as with a pump) in such a way as to make the outlet flow independent of the liquid level. So now F_1 is the control variable and F_0 will be the disturbance variable. The overall material balance becomes:

$$A \frac{dh'}{dt} = F_0' - F_1' \Rightarrow \bar{h}' = \frac{1}{As} \bar{F}_0' - \frac{1}{As} \bar{F}_1' = \frac{K'_p}{s} \bar{F}_0' - \frac{K'_p}{s} \bar{F}_1'$$

and the block diagram is:

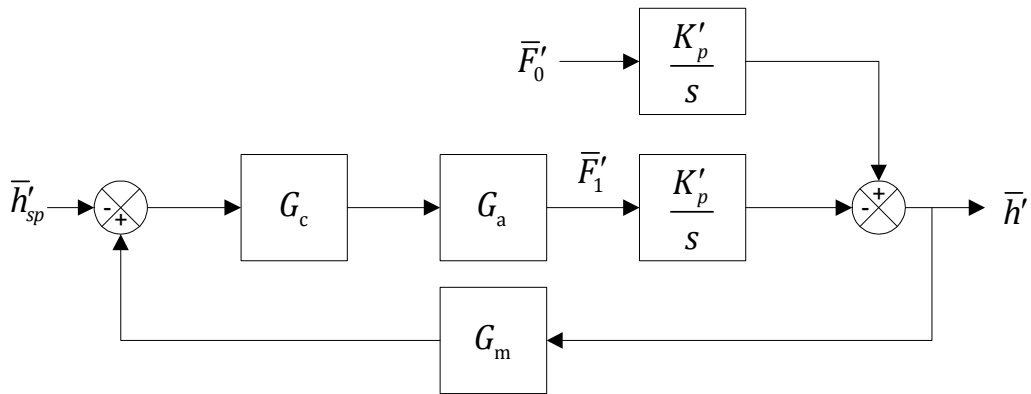

or it can also be drawn as:

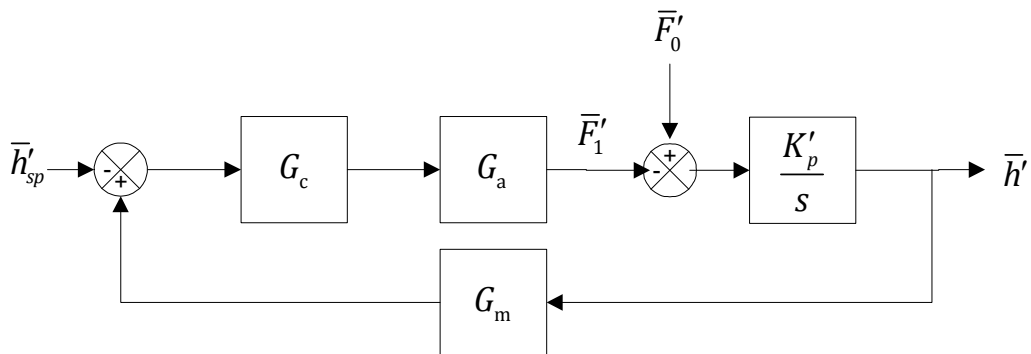

Before we go any further, notice the sign change at the comparator. Normally we define $\bar{\varepsilon} = \bar{h}'_r - \bar{h}'_m$, **but here we have changed the sign!** This is because using F_1 to control the

liquid level gives what can be thought of as an inverse control type. Normally, if the measured variable is too small, then the manipulated variable must be increased (e.g., if the temperature in a tank is too low, then the heat to the tank is increased). For the 1st case, control using F_0 , if the level is too high, then the flow in must be decreased; if the level is too low, then flow in must be increased. However, here we must go in the opposite direction. If the level is too high, then the flow out must be increased; if the level is too low, then flow out must be decreased. In the block diagram, this logic can be accommodated either by making the control transfer function negative or by changing the signs at the comparator.

For the 1st case, using the inlet flow as the manipulated variable, the overall transfer function between the set point and the liquid level will be:

$$\frac{\bar{h}'}{\bar{h}'_R} = \frac{G_c G_v G_p}{1 + G_c G_v G_p G_m} = \frac{G_c G_v \frac{K_p}{\tau_p s + 1}}{1 + G_c G_v G_m \frac{K_p}{\tau_p s + 1}} = \frac{G_c G_v K_p}{\tau_p s + 1 + K_p G_c G_v G_m}$$

For the 2nd case, using the outlet flow as the manipulated variable, the overall transfer function will be:

$$\frac{\bar{h}'}{\bar{h}'_R} = \frac{G_c G_v G_p}{1 + G_c G_v G_p G_m} = \frac{G_c G_v \frac{K'_p}{s}}{1 + G_c G_v G_m \frac{K'_p}{s}} = \frac{G_c G_v K'_p}{K'_p G_c G_v G_m + s}$$

Notice that the positions of the negative signs have changed. The other major difference is the form of the process transfer function, G_p .

Typical controller strategies

Typical controller strategies and parameter values (SEM pg. 197):

- *Proportional (P) control*. Controller output will be:

$$P(t) = K_c E(t) + P_s \Rightarrow P'(t) = K_c E(t)$$

where K_c is the *controller gain* and P_s is the *controller bias*. The gain is sometimes referred to as *proportional band PB* where $PB = 100/K_c$ and typically kept in range $1 \leq PB \leq 1000$. This controller's transfer function is:

$$G_c(s) = K_c$$

- *Proportional-integral (PI) control*. Controller output will be:

$$P(t) = K_c E(t) + \frac{K_c}{\tau_I} \int_0^t E(\tau) d\tau + P_s \Rightarrow P'(t) = K_c E'(t) + \frac{K_c}{\tau_I} \int_0^t E'(\tau) d\tau$$

where τ_I is the *integral time constant* or *reset time*. This is typically set within the range $0.02 \leq \tau_I \leq 20$ min. This controller's transfer function is:

$$G_c(s) = K_c \left(1 + \frac{1}{\tau_I s} \right)$$

- *Proportional-integral-derivative (PID) control*. Controller output will be:

$$P(t) = K_c E(t) + \frac{K_c}{\tau_I} \int_0^t E(\tau) d\tau + K_c \tau_D \frac{dE}{dt} + P_s$$

where τ_D is the *derivative time constant*. The derivative portion of the control anticipates what the error will be in the immediate future — sometimes referred to as *anticipatory control*. This is typically set within the range $0.1 \leq \tau_D \leq 10$ min. This controller's transfer function is:

$$G_c(s) = K_c \left(1 + \frac{1}{\tau_I s} + \tau_D s \right).$$

Derivative control can give a sudden “kick” when step changes are introduced. To get around this, industrial controllers will actually implement derivative control in an approximate manner:

$$G_c(s) = K_c \left(1 + \frac{1}{\tau_I s} + \frac{\tau_D s}{\alpha \tau_D s + 1} \right)$$

where α is a constant between 0.05 and 0.2, most typically 0.1.

Another way to eliminate the derivative kick is to apply the derivative action to the measured value of the output, not the error. In this case the signal out of the controller will be:

$$\bar{C}' = K_c \left(1 + \frac{1}{\tau_I s} \right) \bar{e}' + K_c \left(\frac{\tau_D s}{\alpha \tau_D s + 1} \right) \bar{y}_m'.$$

The closed loop block diagram for this type of controller can be expressed like that in the following diagram.

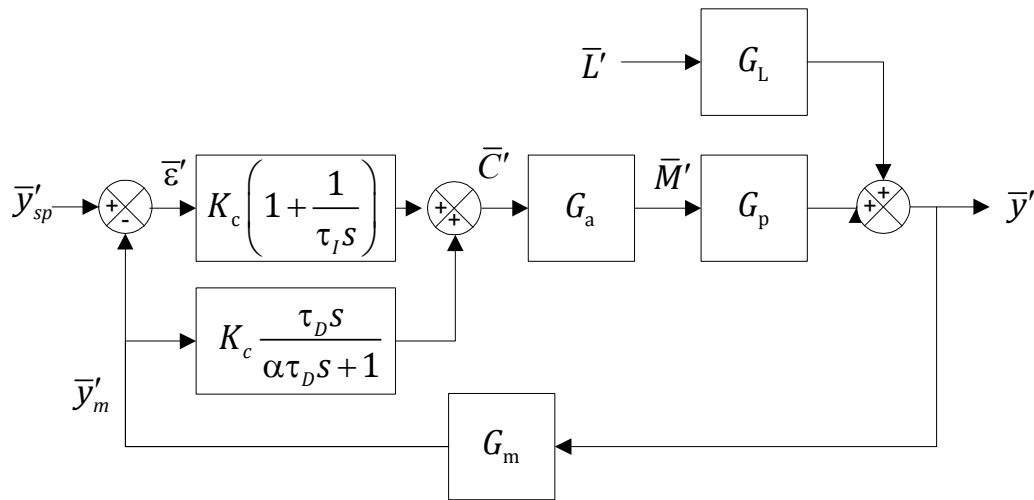

Sometimes, especially with pneumatic transmission lines, there may be a time delay due to signal transmission. This will normally be ignored. However, if the time delay is large enough, then the time delay transfer function will be:

$$\frac{\bar{P}_0(s)}{\bar{P}_i(s)} = \frac{e^{-\tau_d s}}{\tau_p s + 1}.$$

Effect of Controller Strategies on First Order Process

The controller strategies will have different characteristic effects on a process. A first order process with one manipulated variable and one load will be used to show these effects. Both transfer functions will use the same time constant, τ_p , but different process gains. The underlying ODE and resulting transfer functions will be:

$$\begin{aligned} \tau_p \frac{dy'}{dt} + y' &= K_p M' + K_L L' \Rightarrow \bar{y}' = \frac{K_p}{\tau_p s + 1} \bar{M}' + \frac{K_L}{\tau_p s + 1} \bar{L}' \\ &= G_p \bar{M}' + G_L \bar{L}' \end{aligned}$$

Another simplification used here will be to neglect appreciable dynamics from the measuring device & the final control element, i.e., $G_m = G_a = 1$.

Effect of Proportional Control

For proportional (P) control:

$$G_c(s) = K_c$$

And the overall transfer function will be:

$$\begin{aligned}
\bar{y}' &= \frac{G_p K_c}{1 + G_p K_c} \bar{y}'_{sp} + \frac{G_L}{1 + G_p K_c} \bar{L}' = \frac{\frac{K_p}{\tau_p s + 1} K_c}{1 + \frac{K_p}{\tau_p s + 1} K_c} \bar{y}'_{sp} + \frac{\frac{K_L}{\tau_p s + 1}}{1 + \frac{K_p}{\tau_p s + 1} K_c} \bar{L}' \\
&= \frac{K_p K_c}{\tau_p s + 1 + K_p K_c} \bar{y}'_{sp} + \frac{K_L}{\tau_p s + 1 + K_p K_c} \bar{L}' \\
&= \frac{\left(\frac{K_p K_c}{1 + K_p K_c} \right)}{\left(\frac{\tau_p}{1 + K_p K_c} \right) s + 1} \bar{y}'_{sp} + \frac{\left(\frac{K_L}{1 + K_p K_c} \right)}{\left(\frac{\tau_p}{1 + K_p K_c} \right) s + 1} \bar{L}' \\
&= \frac{K'_p}{\tau'_p s + 1} \bar{y}'_{sp} + \frac{K'_L}{\tau'_p s + 1} \bar{L}'
\end{aligned}$$

where: $\tau'_p \equiv \frac{\tau_p}{1 + K_p K_c}$

$$K'_p \equiv \frac{K_p K_c}{1 + K_p K_c}$$

$$K'_L \equiv \frac{K_L}{1 + K_p K_c}$$

What are the implications of this?

- The response of the system remains 1st order.
- The time constant has been decreased ($\tau'_p < \tau_p$) meaning that the response of the system is faster.
- The process gains have decreased.
- There will be an offset at the new ultimate value of the response.

The last item is not immediately obvious from the response expression. First, let us define the offset as the difference between a steady state response, y_∞ , and the corresponding set point:

$$\text{Offset} \equiv y_{sp} - y_\infty = (y'_{sp} + y_{sp}^*) - (y'_\infty + y_{sp}^*) = y'_{sp} - y'_\infty$$

where the expression can be put in terms of deviation variables if the initial steady state is at the initial set point. For a change in the set point and/or the load we can determine the new steady state value by applying the Final Value Theorem.

- For a step change in the set point of $y'_{sp} = \Delta y_{sp}$ then the set point's dynamic function will be:

$$\bar{y}'_{sp} = \frac{\Delta y_{sp}}{s},$$

the dynamic response of the output will be:

$$\bar{y}' = \frac{K'_p}{\tau'_p s + 1} \bar{y}'_{sp} = \frac{K'_p}{\tau'_p s + 1} \frac{\Delta y_{sp}}{s},$$

the ultimate value will be:

$$y'_{\infty} = \lim_{t \rightarrow \infty} [y'] = \lim_{s \rightarrow 0} [s \cdot \bar{y}'] = \lim_{s \rightarrow 0} \left[s \cdot \frac{K'_p}{\tau'_p s + 1} \frac{\Delta y_{sp}}{s} \right] = K'_p \Delta y_{sp},$$

and the offset will be:

$$\begin{aligned} \text{Offset} &= \Delta y_{sp} - K'_p \Delta y_{sp} = (1 - K'_p) \Delta y_{sp} \\ &= \left(1 - \frac{K'_p K_c}{1 + K'_p K_c} \right) \Delta y_{sp} = \left(\frac{1}{1 + K'_p K_c} \right) \Delta y_{sp}. \end{aligned}$$

We would like the offset to be zero, but this is not possible unless $K_c \rightarrow \infty$.

- For a step change in the load without a change in set point then $y'_{sp} = \Delta y_{sp} = 0$ and $L' = \Delta L$. The load's dynamic function will be:

$$\bar{L}' = \frac{\Delta L}{s},$$

the dynamic response of the output will be:

$$\bar{y}' = \frac{K'_L}{\tau'_p s + 1} \bar{L}' = \frac{K'_L}{\tau'_p s + 1} \frac{\Delta L}{s},$$

the ultimate value will be:

$$y'_{\infty} = \lim_{t \rightarrow \infty} [y'] = \lim_{s \rightarrow 0} [s \cdot \bar{y}'] = \lim_{s \rightarrow 0} \left[s \cdot \frac{K'_L}{\tau'_p s + 1} \frac{\Delta L}{s} \right] = K'_L \Delta L,$$

and the offset will be:

$$\text{Offset} = -K'_L \Delta L = \left(\frac{K_L}{1 + K_p K_c} \right) \Delta L.$$

Again, we would like the offset to be zero, but again this is not possible unless $K_c \rightarrow \infty$.

The offset is characteristic of P control. The only time when there will be no offset is when the process transfer function has an integrating factor (i.e., a $1/s$ factor). For example, if the first order process is actually a pure integrator, then $G_p = K'_p / s$, the transfer function between the set point & the output will be:

$$\bar{y}' = \frac{G_p K_c}{1 + G_p K_c} \bar{y}'_{sp} = \frac{\frac{K'_p}{s} K_c}{1 + \frac{K'_p}{s} K_c} \bar{y}'_{sp} = \frac{K'_p K_c}{s + K'_p K_c} \bar{y}'_{sp},$$

and the ultimate value of the response to a step change in the set point will be:

$$y'_\infty = \lim_{s \rightarrow 0} [s \cdot \bar{y}'] = \lim_{s \rightarrow 0} \left[s \cdot \frac{K'_p K_c}{s + K'_p K_c} \frac{\Delta \bar{y}'_{sp}}{s} \right] = \frac{K'_p K_c}{K'_p K_c} \cdot \Delta \bar{y}'_{sp} = \Delta \bar{y}'_{sp}$$

which leads to a zero offset.

Effect of PI Control

For proportional-integral (PI) control:

$$G_c(s) = K_c \left(1 + \frac{1}{\tau_I s} \right)$$

then:

$$\begin{aligned}
\bar{y}' &= \frac{\frac{K_p}{\tau_p s + 1} K_c \left(1 + \frac{1}{\tau_I s}\right)}{1 + \frac{K_p}{\tau_p s + 1} K_c \left(1 + \frac{1}{\tau_I s}\right)} \bar{y}'_{sp} + \frac{\frac{K_L}{\tau_p s + 1}}{1 + \frac{K_p}{\tau_p s + 1} K_c \left(1 + \frac{1}{\tau_I s}\right)} \bar{L}' \\
&= \frac{K_p K_c (\tau_I s + 1)}{\tau_I s (\tau_p s + 1) + K_p K_c (\tau_I s + 1)} \bar{y}'_{sp} + \frac{K_L \tau_I s}{\tau_I s (\tau_p s + 1) + K_p K_c (\tau_I s + 1)} \bar{L}' \\
&= \frac{K_p K_c (\tau_I s + 1)}{\tau_p \tau_I s^2 + \tau_I (1 + K_p K_c) s + K_p K_c} \bar{y}'_{sp} + \frac{K_L \tau_I s}{\tau_p \tau_I s^2 + \tau_I (1 + K_p K_c) s + K_p K_c} \bar{L}' \\
&= \frac{\tau_I s + 1}{\left(\frac{\tau_p \tau_I}{K_p K_c}\right) s^2 + \tau_I \left(1 + \frac{1}{K_p K_c}\right) s + 1} \bar{y}'_{sp} + \frac{\left(\frac{K_L \tau_I}{K_p K_c}\right) s}{\left(\frac{\tau_p \tau_I}{K_p K_c}\right) s^2 + \tau_I \left(1 + \frac{1}{K_p K_c}\right) s + 1} \bar{L}'
\end{aligned}$$

Note the transfer functions have increased by an order of 1 (from 1st order to 2nd order). The parameters for the 2nd order system are:

$$\begin{aligned}
\tau' &= \sqrt{\frac{\tau_p \tau_I}{K_p K_c}} \\
\zeta' &= \frac{\tau_I}{2} \left(1 + \frac{1}{K_p K_c}\right) \sqrt{\frac{K_p K_c}{\tau_p \tau_I}} = \frac{1}{2} \frac{K_p K_c + 1}{\sqrt{K_p K_c}} \sqrt{\frac{\tau_I}{\tau_p}}
\end{aligned}$$

so the transfer functions could also be expressed as:

$$\bar{y}' = \frac{\tau_I s + 1}{(\tau')^2 s^2 + 2\tau'\zeta' s + 1} \bar{y}'_{sp} + \frac{\left(\frac{K_L \tau_I}{K_p K_c}\right) s}{(\tau')^2 s^2 + 2\tau'\zeta' s + 1} \bar{L}'$$

Both of the transfer functions have an “s” term in the numerator so they are more complicated than what we have been dealing with up to now. But these terms lead to the property that PI control has zero offset for changes in both the set point and the load. For example, for a step change in the set point of $y'_{sp} = \Delta y_{sp}$ then the dynamic response of the output will be:

$$\bar{y}' = \frac{\tau_I s + 1}{(\tau')^2 s^2 + 2\tau'\zeta' s + 1} \cdot \frac{\Delta y_{sp}}{s}$$

the ultimate value will be:

$$y'_{\infty} = \lim_{t \rightarrow \infty} [y'] = \lim_{s \rightarrow 0} [s \cdot \bar{y}'] = \lim_{s \rightarrow 0} \left[s \cdot \frac{\tau_I s + 1}{(\tau')^2 s^2 + 2\tau' \zeta' s + 1} \cdot \frac{\Delta y_{sp}}{s} \right] = \Delta y_{sp},$$

and the offset will be:

$$\text{Offset} = \Delta y_{sp} - \Delta y_{sp} = 0.$$

The an “s” terms in the numerators will change the expected form of the response curves from “standard” 2nd order system responses.

- For the load, the response will be the derivative of the standard 2nd order response to the driving function. For a ramp change to the load, the response will look like the standard response to a step-change driving function. For a step change in the load, the response will look like the standard response to an impulse driving function:

$$\bar{y}' = \frac{\left(\frac{K_L \tau_I}{K_p K_c} \right) s}{(\tau')^2 s^2 + 2\tau' \zeta' s + 1} \frac{\Delta L'}{s} = \frac{\left(\frac{K_L \tau_I}{K_p K_c} \right) (\Delta L')}{(\tau')^2 s^2 + 2\tau' \zeta' s + 1}.$$

- For the set point, the response have two parts: the standard response with a gain of one & the derivative of the standard 2nd order response to the driving function. The derivative part will die out after a short period of time leaving the standard response as the long-time solution. For a step change in the set point this will look like a step-change response plus an impulse response:

$$\bar{y}' = \frac{\tau_I s + 1}{(\tau')^2 s^2 + 2\tau' \zeta' s + 1} \cdot \frac{\Delta y_{sp}}{s} = \frac{1}{(\tau')^2 s^2 + 2\tau' \zeta' s + 1} \cdot \frac{\Delta y_{sp}}{s} + \frac{\tau_I (\Delta y_{sp})}{(\tau')^2 s^2 + 2\tau' \zeta' s + 1}.$$

Depending upon the combination of $K_c K_p$ and τ_I / τ_p the system will be overdamped, underdamped, or critically damped. The following figure shows the relationship of the damping factor ζ' to these parameters. Note that for a given τ_I value there is a minimum ζ' for an adjustment of K_c .

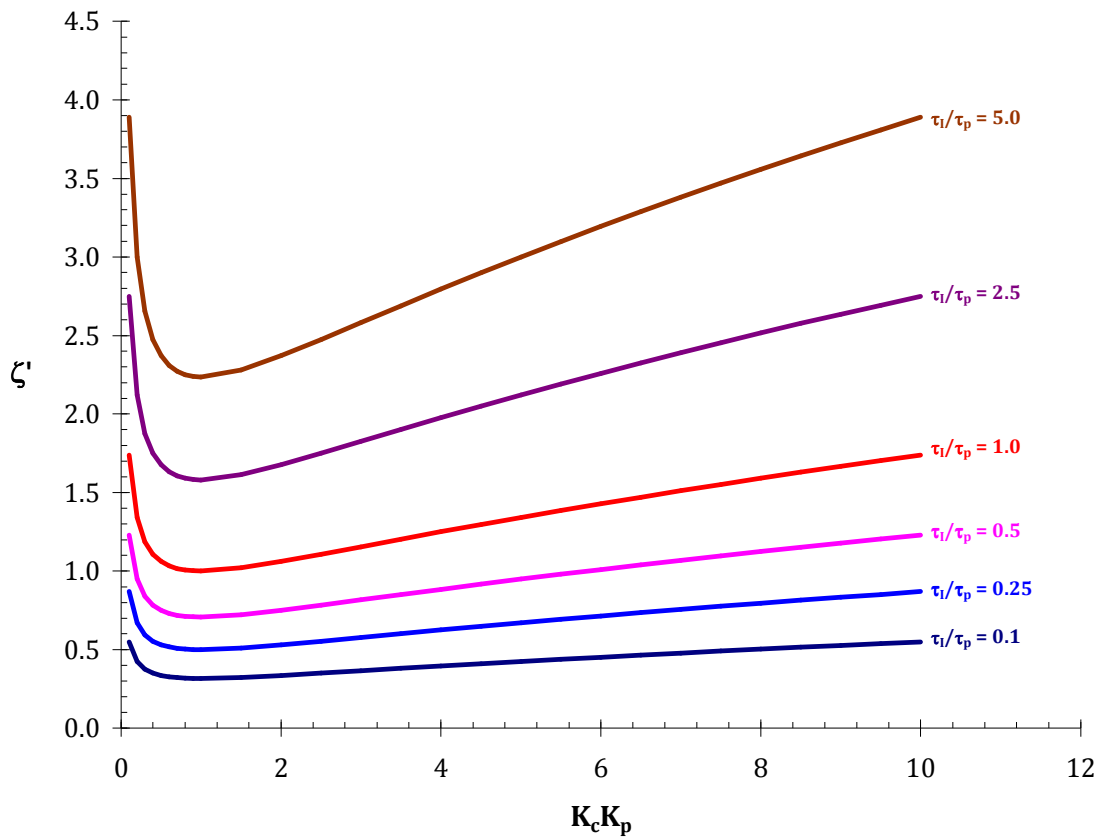

Effect of PID Control

For proportional-integral-derivative (PID) control:

$$G_c(s) = K_c \left(1 + \frac{1}{\tau_I s} + \tau_D s \right)$$

then:

$$\begin{aligned}
\bar{y}' &= \frac{\frac{K_p}{\tau_p s + 1} K_c K_c \left(1 + \frac{1}{\tau_I s} + \tau_D s\right)}{1 + \frac{K_p}{\tau_p s + 1} K_c K_c \left(1 + \frac{1}{\tau_I s} + \tau_D s\right)} \bar{y}'_{sp} + \frac{\frac{K_L}{\tau_p s + 1}}{1 + \frac{K_p}{\tau_p s + 1} K_c K_c \left(1 + \frac{1}{\tau_I s} + \tau_D s\right)} \bar{L}' \\
&= \frac{K_p K_c (\tau_I s + 1 + \tau_I \tau_D s^2)}{\tau_I s (\tau_p s + 1) + K_p K_c (\tau_I s + 1 + \tau_I \tau_D s^2)} \bar{y}'_{sp} + \frac{K_L \tau_I s}{\tau_I s (\tau_p s + 1) + K_p K_c (\tau_I s + 1 + \tau_I \tau_D s^2)} \bar{L}' \\
&= \frac{K_p K_c (\tau_I \tau_D s^2 + \tau_I s + 1)}{(\tau_p \tau_I + \tau_I \tau_D K_p K_c) s^2 + \tau_I (1 + K_p K_c) s + K_p K_c} \bar{y}'_{sp} + \frac{K_L \tau_I s}{(\tau_p \tau_I + \tau_I \tau_D K_p K_c) s^2 + \tau_I (1 + K_p K_c) s + K_p K_c} \bar{L}' \\
&= \frac{\tau_I \tau_D s^2 + \tau_I s + 1}{\left(\frac{\tau_p \tau_I + \tau_I \tau_D K_p K_c}{K_p K_c}\right) s^2 + \tau_I \left(1 + \frac{1}{K_p K_c}\right) s + 1} \bar{y}'_{sp} + \frac{\left(\frac{K_L \tau_I}{K_p K_c}\right) s}{\left(\frac{\tau_p \tau_I + \tau_I \tau_D K_p K_c}{K_p K_c}\right) s^2 + \tau_I \left(1 + \frac{1}{K_p K_c}\right) s + 1} \bar{L}'
\end{aligned}$$

Note that the integral action has increased the order of the transfer functions by 1 (from 1st order to 2nd order); the derivative action does not affect this. The parameters for the 2nd order system are:

$$\begin{aligned}
\tau' &= \sqrt{\frac{\tau_p \tau_I + \tau_I \tau_D K_p K_c}{K_p K_c}} \\
\zeta' &= \frac{\tau_I}{2} \left(1 + \frac{1}{K_p K_c}\right) \sqrt{\frac{K_p K_c}{\tau_p \tau_I + \tau_I \tau_D K_p K_c}} = \frac{1}{2} \frac{K_p K_c + 1}{\sqrt{K_p K_c}} \sqrt{\frac{(\tau_I / \tau_p)}{1 + (K_p K_c)(\tau_D / \tau_p)}}
\end{aligned}$$

so the transfer functions could also be expressed as:

$$\bar{y}' = \frac{\tau_I \tau_D s^2 + \tau_I s + 1}{(\tau')^2 s^2 + 2\tau' \zeta' s + 1} \bar{y}'_{sp} + \frac{\left(\frac{K_L \tau_I}{K_p K_c}\right) s}{(\tau')^2 s^2 + 2\tau' \zeta' s + 1} \bar{L}'$$

The derivative action will increase the characteristic time τ' but decrease the damping factor ζ' . The first action will slow down the response but the second will speed it up. Both affects must be combined to determine the overall affect.

Both of the transfer functions have “s” terms in the numerator that lead to zero offsets (primarily from the integral action). The form of the response curve to a load change will be identical to that for PI control. The response for a set point change, however, has an additional short-time contribution that looks like the 2nd derivative of the forcing function's

response. For example, for a step change in the set point of $y'_{sp} = \Delta y_{sp}$ the dynamic response of the output can be determined from:

$$\begin{aligned} \bar{y}' &= \frac{\tau_I \tau_D s^2 + \tau_I s + 1}{(\tau')^2 s^2 + 2\tau' \zeta' s + 1} \cdot \frac{\Delta y_{sp}}{s} \\ &= \frac{1}{(\tau')^2 s^2 + 2\tau' \zeta' s + 1} \cdot \frac{\Delta y_{sp}}{s} + \frac{\tau_I (\Delta y_{sp})}{(\tau')^2 s^2 + 2\tau' \zeta' s + 1} + \frac{(\tau_I \tau_D) (\Delta y_{sp}) s}{(\tau')^2 s^2 + 2\tau' \zeta' s + 1} \end{aligned}$$