

Stability Analysis of Feedback Control Systems

Stability Analysis of Feedback Control Systems	1
Introduction	1
Routh-Hurwitz Stability Criterion	2
Example #1	4
Direct Substitution	6
Example #1 by Direct Substitution	6
Example with P & PI Control	7
Example with Dead Time	11
Root-Locus Analysis	13

Introduction

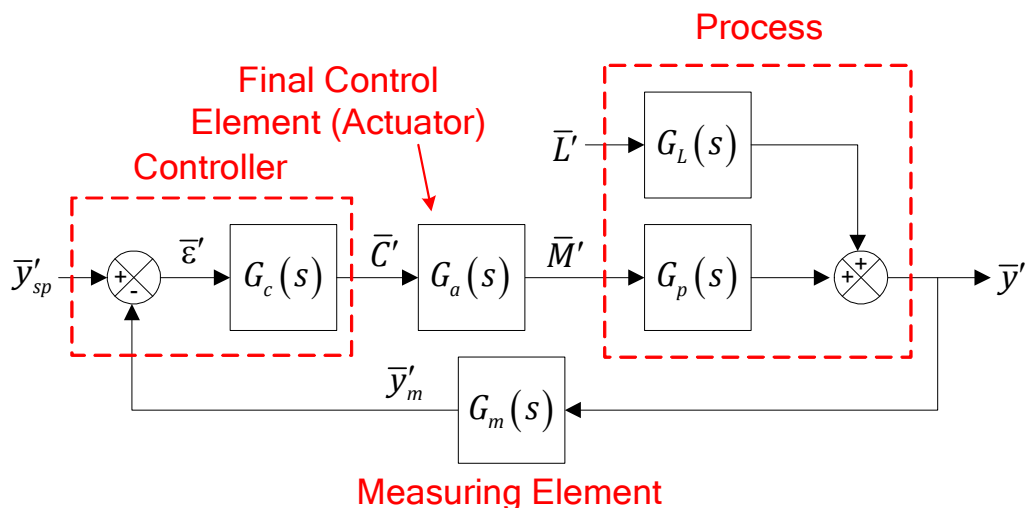

Remember that for the generalized closed-loop system shown above the overall transfer function is:

$$\bar{y} = \frac{G_p G_f G_c}{1 + G_p G_f G_c G_m} \bar{y}_{sp} + \frac{G_d}{1 + G_p G_f G_c G_m} \bar{d}$$

where: $G_{sp} = \frac{G_p G_f G_c}{1 + G_p G_f G_c G_m}$ and $G_{load} = \frac{G_d}{1 + G_p G_f G_c G_m}$

Review the section **Poles & Zeros** in the notes **Transfer Functions** for a discussion of process stability. The definition of stability we will use for *bounded input, bounded output stability* is:

A dynamic system is considered stable if for every bounded input it produces a bounded output, regardless of its initial state.

The stability will be dictated by the characteristic poles of the transfer functions G_{sp} and G_{load} . The characteristic equation to give these poles is the same (since the denominator is the same):

$$1 + G_p G_f G_c G_m = 0.$$

Note that if the control is cut right before the comparator, we get the *open loop transfer function*:

$$\frac{\bar{y}_m}{\bar{y}_{sp}} = G_p G_f G_c G_m = G_{OL}$$

so the characteristic equation can be written as:

$$1 + G_{OL} = 0.$$

For example, a process with a transfer function $G_p = 1/(s-1)$ is unstable since it has a positive pole $s = +1$. However, let's put in a P controller with $G_m = G_f = 1$. Then, the closed loop characteristic equation will be:

$$1 + \frac{1}{s-1} \cdot 1 \cdot K_c \cdot 1 = 0 \Rightarrow s - 1 + K_c = 0.$$

Now, the pole is at $s = 1 - K_c$. This will be a stable dynamic system if $\text{Re}(s) = s < 0$, or:

$$1 - K_c < 0 \Rightarrow K_c > 1.$$

Routh-Hurwitz Stability Criterion

We do not necessarily need to know the poles to determine stability — just the knowledge of which side of the complex plane the poles lie may be enough. We can set up a *Routh array* to determine this. The steps are:

- Express the characteristic equation as an expanded polynomial:

$$\pm(1 + G_p G_f G_c G_m) = a_n s^n + a_{n-1} s^{n-1} + \dots + a_1 s + a_0.$$

where $a_0 > 0$. This subscript notation is different from many other texts that use:

$$\pm(1 + G_p G_f G_c G_m) = a_0 s^n + a_1 s^{n-1} + \dots + a_{n-1} s + a_n.$$

- If any of the coefficients are negative, then there is at least one root with a positive real part and the system is unstable.
- Set up a table that looks like the following:

Row				
1	a_n	a_{n-2}	a_{n-4}	a_{n-6}
2	a_{n-1}	a_{n-3}	a_{n-5}	a_{n-7}
3	b_1	b_2	b_3	
4	c_1	c_2	c_3	
5	d_1	d_2		
6	e_1	e_2		

where the elements are found from equations like:

$$b_1 = \frac{a_{n-1} a_{n-2} - a_n a_{n-3}}{a_{n-1}} = a_{n-2} - \frac{a_n a_{n-3}}{a_{n-1}}$$

$$b_2 = \frac{a_{n-1} a_{n-4} - a_n a_{n-5}}{a_{n-1}} = a_{n-4} - \frac{a_n a_{n-5}}{a_{n-1}}$$

$$c_1 = \frac{b_1 a_{n-3} - a_1 b_2}{b_1} = a_{n-3} - \frac{a_1 b_2}{b_1}$$

$$c_2 = \frac{b_1 a_{n-5} - a_{n-1} b_3}{b_1} = a_{n-5} - \frac{a_{n-1} b_3}{b_1}$$

The rule is to look at the square matrix above the element to be calculated. **Use the values from column 1 & the column just to the right of the element of interest.** Multiply the off diagonal terms, subtract the product of the diagonal terms, and divide by the element just above. So, for example, term d_2 will be:

$$d_2 = \frac{c_1 b_3 - b_1 c_3}{c_1} = b_3 - \frac{b_1 c_3}{c_1} \dots$$

- If all of the elements in the 1st column are positive, then the system is stable.
- If some of the elements in the 1st column are negative, the number of roots with a positive real part will be equal to the number of sign changes in the 1st column.

We can use the criteria to pick valid controller parameters that keep the system stable.

Example #1

In the following system, determine the value of the gain that makes the system unstable if (a) $\tau_D = 0.25$ min and (b) $\tau_D = 0.5$ min. Use the following data:

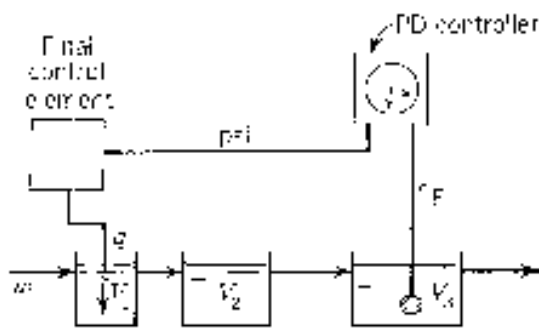

- $\dot{m} = 250$ lb/min
- $\rho = 62.5$ lb/ft³
- $V_1 = 4$ ft³
- $V_2 = 5$ ft³
- $V_3 = 6$ ft³
- $\hat{C}_p = 1$ Btu/lb°F

The energy balance around each tank will be:

$$\frac{d(\rho V_i \hat{H}_i)}{dt} = \dot{m} \hat{H}_{i-1} - \dot{m} \hat{H}_i + Q_i \Rightarrow \rho V_i \hat{C}_p \frac{dT_i}{dt} = \dot{m} \hat{C}_p (T_{i-1} - T_i) + Q_i$$

So, in terms of deviation variables & taking the Laplace transform we get 1st order systems of the form:

$$\bar{T}'_i = \frac{1}{\tau_i s + 1} \bar{T}'_{i-1} + \frac{K_q}{\tau_i s + 1} \bar{Q}'_i \text{ where } \tau_i = \frac{\rho V_i}{\dot{m}} \text{ \& } K_q = \frac{1}{\dot{m} \hat{C}_p}$$

and where $\bar{Q}'_2 = \bar{Q}'_3 = 0$ since there are no heaters in these tanks. The following information block diagram shows the feedback control system.

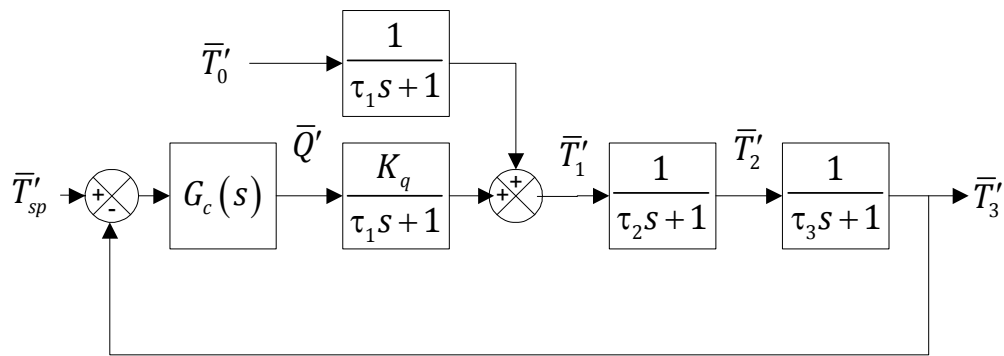

The system parameters will be:

$$K_1 = \frac{1}{\dot{m}\hat{C}_p} = \frac{1}{250 \cdot 1} = 0.004 \text{ } ^\circ\text{F}/(\text{Btu}/\text{min})$$

$$\tau_1 = \frac{\rho V_1}{\dot{m}} = \frac{62.5 \cdot 4}{250} = 1.00 \text{ min}$$

$$\tau_2 = \frac{\rho V_2}{\dot{m}} = \frac{62.5 \cdot 5}{250} = 1.25 \text{ min}$$

$$\tau_3 = \frac{\rho V_3}{\dot{m}} = \frac{62.5 \cdot 6}{250} = 1.50 \text{ min}$$

The characteristic equation will be:

$$\begin{aligned} 1 + G_c G_f G_1 G_2 G_3 &= 1 + K_c (1 + \tau_D s) \frac{K_1}{\tau_1 s + 1} \frac{1}{\tau_2 s + 1} \frac{1}{\tau_3 s + 1} \\ &= 1 + K_c (1 + \tau_D s) \frac{0.004}{s + 1} \frac{1}{1.25s + 1} \frac{1}{1.50s + 1} \\ (s + 1)(1.25s + 1)(1.50s + 1) + 0.004K_c (1 + \tau_D s) &= 0 \\ 1.875s^3 + 4.625s^2 + 3.75s + 1 + 0.004\tau_D K_c s + 0.004K_c &= 0 \end{aligned}$$

The Routh array will be:

Row	1	2
1	1.875	$3.75 + 0.004K_c\tau_D$
2	4.625	$1 + 0.004K_c$
3	$\frac{4.625(3.75 + 0.004K_c\tau_D) - 1.875(1 + 0.004K_c)}{4.625}$	
4	$1 + 0.004K_c$	

The important element is:

$$\frac{4.625(3.75 + 0.004K_c\tau_D) - 1.875(1 + 0.004K_c)}{4.625} = 3.345 + 0.004K_c\tau_D - 0.00162K_c$$

So, the system will be stable as long as:

$$\begin{aligned} 3.345 + 0.004K_c\tau_D - 0.00162K_c &> 0 \\ (0.00162 - 0.004\tau_D)K_c &< 3.345 \end{aligned}$$

So: for $\tau_D = 0.25$, $0.00062K_c < 3.345 \Rightarrow K_c < 5380$ — this case has conditional stability.
 For $\tau_D = 0.50$, $-0.00038K_c < 3.345 \Rightarrow K_c > -8800$ — this case has unconditional stability.

Direct Substitution

The direct substitution method can give both the ultimate values of the controller settings and the period of oscillation at the ultimate settings. It can also be applied to systems with dead time without having to make any approximations to the e^{-0s} term.

The procedure is to substitute $s = j\omega$ (where $j \equiv \sqrt{-1}$) and set the real & imaginary parts to zero. These expressions will give the ultimate values for ω (the frequency of oscillation at this stability limit) & the associated controller settings. A time delay term poses no problems since:

$$e^{-j\omega\theta} = \cos(\omega\theta) - j\sin(\omega\theta).$$

Example #1 by Direct Substitution

For the previous example the characteristic equation was:

$$1.875s^3 + 4.625s^2 + 3.75s + 1 + 0.004\tau_D K_c s + 0.004K_c = 0$$

Substituting $s = j\omega$:

$$\begin{aligned} 1.875(j\omega)^3 + 4.625(j\omega)^2 + 3.75(j\omega) + 1 + 0.004\tau_D K_c(j\omega) + 0.004K_c &= 0 \\ -1.875j\omega^3 - 4.625\omega^2 + 3.75j\omega + 1 + 0.004\tau_D K_c j\omega + 0.004K_c &= 0 \\ (1 + 0.004K_c - 4.625\omega^2) + j\omega(3.75 + 0.004\tau_D K_c - 1.875\omega^2) &= 0 \end{aligned}$$

From the imaginary part:

$$3.75 + 0.004\tau_D K_{cu} - 1.875\omega^2 = 0 \Rightarrow \omega^2 = \frac{3.75 + 0.004\tau_D K_{cu}}{1.875}$$

and from the real part:

$$1 + 0.004K_{cu} - 4.625\omega^2 = 0 \Rightarrow K_{cu} = \frac{4.625\omega^2 - 1}{0.004}.$$

Or we can use the result from the imaginary part first:

$$\begin{aligned} 1 + 0.004K_{cu} - 4.625\left(\frac{3.75 + 0.004\tau_D K_{cu}}{1.875}\right) &= 0 \\ 1 + 0.004K_c - \frac{4.625 \cdot 3.75}{1.875} - \frac{4.625 \cdot 0.004\tau_D K_c}{1.875} &= 0 \\ \left(0.004 - \frac{4.625 \cdot 0.004\tau_D}{1.875}\right)K_{cu} &= \frac{4.625 \cdot 3.75}{1.875} - 1 \\ K_{cu} &= \frac{4.625 \cdot 3.75 - 1.875}{0.004 \cdot 1.875 - 4.625 \cdot 0.004\tau_D} = \frac{3,867}{1.875 - 4.625\tau_D}. \end{aligned}$$

So, for $\tau_D = 0.25$, $K_{cu} = 5380$ which is what we found previously. Next, for $\tau_D = 0.50$, $K_{cu} = -8839$ — it is not immediately obvious how to interpret that, but we know from the Routh array analysis that this is a lower limit on K_c , so this case has unconditional stability.

Example with P & PI Control

Let's consider the following example where the actuator & measurement devices have non-negligible dynamics.

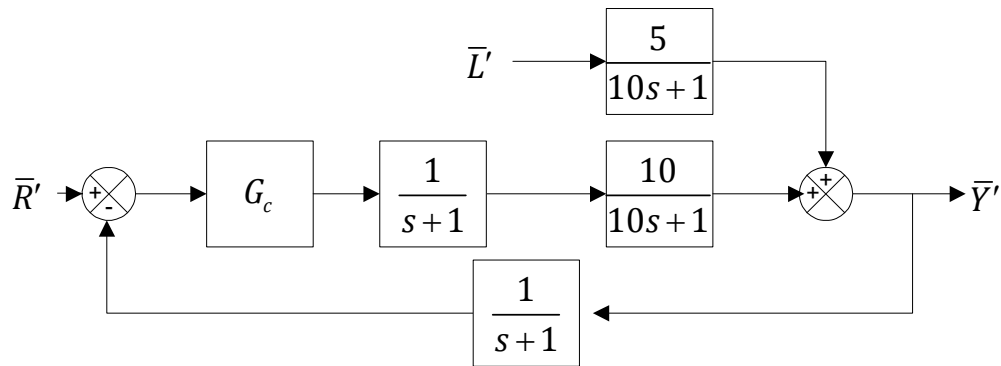

For this problem the characteristic equation will be:

$$1 + G_c \frac{1}{s+1} \cdot \frac{1}{s+1} \cdot \frac{10}{10s+1} = 0$$

$$(s+1)^2(10s+1) + 10G_c = 0$$

$$10s^3 + 21s^2 + 12s + 1 + 10G_c = 0$$

P Control – Routh Array Analysis. With P control, the characteristic equation is:

$$10 \cdot s^3 + 21 \cdot s^2 + 12 \cdot s + (1 + 10K_c) = 0$$

and the Routh array is as follows:

Row	1	2
1	10	12
2	21	$1 + 10K_c$
3	$12 - \frac{10(1 + 10K_c)}{21}$	
4	$1 + 10K_c$	

Notice that the restriction on K_c from the 4th row is exactly the same as the restriction on K_c from the polynomial's coefficients, namely

$$1 + 10K_c > 0 \Rightarrow K_c > -\frac{1}{10}$$

This is not really a restriction since we are considering only positive values for the controller gain.

However, the 3rd row does give a restriction on K_c :

$$12 - \frac{10(1+10K_c)}{21} > 0 \Rightarrow K_c < \frac{12 \times 21 - 10}{100} = 2.42.$$

There are two important features to the result, (1) the value of the controller gain that will be on the edge of stability and (2) whether this value is a maximum controller gain to be used or a minimum. In this case we see that the ultimate controller gain is a maximum – this is typical of P control – the gain can be small & the larger that it is made, the more likely the system will start going unstable.

P Control – Direct Substitution Analysis. With P control, the characteristic equation with the substitution of $s = \omega j$ is:

$$-10 \cdot \omega^3 j - 21 \cdot \omega^2 + 12 \cdot \omega j + (1 + 10K_c) = 0$$

The imaginary part gives:

$$-10 \cdot \omega_u^3 + 12 \cdot \omega_u = 0 \Rightarrow \omega_u (12 - 10 \cdot \omega_u^2) = 0 \Rightarrow \omega_u^2 = \frac{12}{10} \Rightarrow \omega_u = 2\sqrt{\frac{3}{10}}$$

and the real part gives:

$$-21 \cdot \omega_u^2 + (1 + 10K_{cu}) = 0 \Rightarrow K_c = \frac{21 \cdot \omega_u^2 - 1}{10} = \frac{21 \cdot \frac{12}{10} - 1}{10} = 2.42$$

which is the same ultimate value as found by the Routh array analysis. The only difference between the two techniques is that we are not told whether this K_{cu} value is an upper or lower limit on K_c .

PI Control – Routh Array Analysis. With PI control, the characteristic equation is:

$$10 \cdot s^3 + 21 \cdot s^2 + 12 \cdot s + 1 + 10K_c \left(1 + \frac{1}{\tau_I s} \right) = 0$$
$$10 \cdot s^4 + 21 \cdot s^3 + 12 \cdot s^2 + (1 + 10K_c) s + \frac{10K_c}{\tau_I} = 0$$

and the Routh array is as follows:

Row	1	2	3
1	10	12	$\frac{10K_c}{\tau_I}$
2	21	$1+10K_c$	
3	$12 - \frac{10(1+10K_c)}{21}$	$\frac{10K_c}{\tau_I}$	
4	$1+10K_c - \frac{21 \frac{10K_c}{\tau_I}}{12 - \frac{10(1+10K_c)}{21}}$		
5	$\frac{10K_c}{\tau_I}$		

Here the 3rd row gives us the same restriction on K_c as the P control situation. Now we also have a restriction on the integral time from the 4th row:

$$1+10K_c - \frac{21 \frac{10K_c}{\tau_I}}{12 - \frac{10(1+10K_c)}{21}} > 0 \Rightarrow \tau_I > \frac{4410K_c}{(1+10K_c)(242-100K_c)}$$

There are two things to note here: (1) the ultimate value of τ_I that leads to instability is a minimum value of integral time & (2) the actual value will depend upon whatever value of controller gain is used. That idea that the integral time can be reduced until instability occurs makes intuitive sense, since very large values of τ_I “turns off” the integral action in the PI controller.

One rule-of-thumb states that the K_c value chosen for PI control should be $\frac{1}{2}$ the ultimate value from P control. Using this criteria, K_c here should be 1.21; however, we’ll use $K_c = 1$ to simplify the math. Then the values of τ_I that lead to a stable system are:

$$\tau_I > \frac{4410}{11 \times 142} = 2.82.$$

PI Control – Direct Substitution Analysis. With PI control, the characteristic equation using $K_c = 1$ and with the substitution of $s = \omega j$ is:

$$10 \cdot \omega^4 - 21 \cdot \omega^3 j - 12 \cdot \omega^2 + 11\omega j + \frac{10}{\tau_I} = 0.$$

The imaginary part gives:

$$-21 \cdot \omega_u^3 + 11\omega_u = 0 \Rightarrow (11 - 21 \cdot \omega_u^2)\omega_u = 0 \Rightarrow \omega_u^2 = \frac{11}{21} \Rightarrow \omega_u = \sqrt{\frac{11}{21}}$$

and the real part gives:

$$10 \cdot \omega_u^4 - 12 \cdot \omega_u^2 + \frac{10}{\tau_{lu}} = 0 \Rightarrow \tau_{lu} = \frac{10}{12 \cdot \omega_u^2 - 10 \cdot \omega_u^4} = \frac{10}{12 \cdot \frac{11}{21} - 10 \left(\frac{11}{21}\right)^2} = 2.82$$

which is the same ultimate value as found by the Routh array analysis. Again, the only difference between the two techniques is that we are not told whether this τ_{lu} value is an upper or lower limit on τ_I .

Example with Dead Time

Let's examine the stability of the following system when using P control.

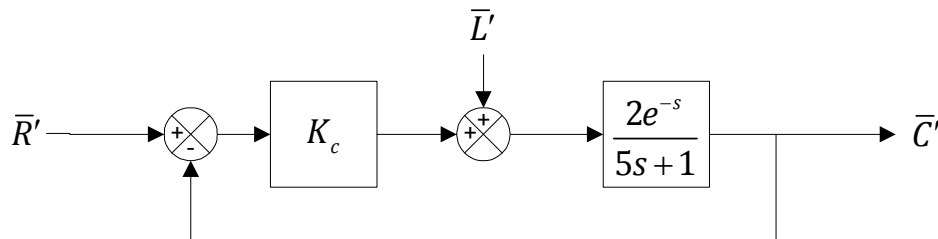

The characteristic equation for the closed loop is:

$$1 + K_c \frac{2e^{-s}}{5s + 1} = 0 \Rightarrow (5s + 1) + 2K_c e^{-s} = 0.$$

Using a 1st order Padé approximation:

$$e^{-\theta s} \approx \frac{1 - \frac{1}{2}\theta s}{1 + \frac{1}{2}\theta s} = \frac{2 - \theta s}{2 + \theta s}$$

the characteristic equation becomes:

$$(5s+1)+2K_c \frac{2-s}{2+s} \approx 0$$

$$(5s+1)(2+s)+2K_c(2-s)=0$$

$$(5s^2+11s+2)+2K_c(2-s)=0$$

$$5s^2+(11-2K_c)s+(2+4K_c)=0.$$

The first limit to stability is the coefficient on the s term. For it to remain positive, then:

$$11-2K_c > 0 \Rightarrow K_c < 5.5.$$

Next, we'll do the full Routh array analysis. The Routh array will be:

Row	1	2
1	5	$2+4K_c$
2	$11-2K_c$	
3	$2+4K_c$	

The stability limit is still controlled by the same coefficient.

Now, let's use the direct substitution method. The characteristic equations becomes:

$$(5\omega j + 1) + 2K_c e^{-\omega j} = 0$$

$$(5\omega j + 1) + 2K_c (\cos \omega - j \sin \omega) = 0$$

$$[1 + 2K_c \cos \omega] + j[5\omega - 2K_c \sin \omega] = 0.$$

The ultimate values can be determined by setting each part equal to zero & doing some algebraic manipulation:

$$1 + 2K_c \cos \omega = 0 \Rightarrow K_{cu} = -\frac{1}{2\cos \omega}$$

and: $5\omega - 2K_{cu} \sin \omega = 0 \Rightarrow 5\omega + \frac{\sin \omega}{\cos \omega} = 0$

$$5\omega + \tan \omega = 0$$

The value for ω must be solved numerically & then substituted in to get K_{cu} . When doing this, we find $\omega = 1.6887$ and $K_{cu} = 4.251$.

Note that the use of 1st order overestimates the ultimate value. One can use higher order approximations to determine what order approximations will give good estimates to K_{cu} . The following table shows estimates using various order Padé approximations (the calculations were performed using *Mathematica*). Notice that the a values from the approximate transfer functions very quickly approach the exact value from the direct substitution method.

Order Padé Approximation	K_{cu}
1 st	5.5
2 nd	4.289
3 rd	4.252
Exact	4.251

Root-Locus Analysis

Can plot in the complex plane the values of the roots of the characteristic equation as the controller parameter change. These **root loci** plots can be useful to determine characteristics of the response of the system.

For example, for two tanks in series with P control, assuming $G_f = G_m = 1$, then:

$$G_p = \frac{K_p}{(\tau_1 s + 1)(\tau_2 s + 1)} \quad \text{and} \quad G_c = K_c$$

and the characteristic equation is:

$$1 + G_c G_p = 1 + \frac{K_c K_p}{(\tau_1 s + 1)(\tau_2 s + 1)} = 0$$

$$(\tau_1 s + 1)(\tau_2 s + 1) + K_c K_p = 0$$

$$\tau_1 \tau_2 s^2 + (\tau_1 + \tau_2)s + 1 + K_c K_p = 0$$

so the roots of this equation are given by:

$$p_1, p_2 = \frac{-(\tau_1 + \tau_2) \pm \sqrt{(\tau_1 + \tau_2)^2 - 4\tau_1 \tau_2 (1 + K_c K_p)}}{2\tau_1 \tau_2}$$

$$= \frac{-(\tau_1 + \tau_2) \pm \sqrt{(\tau_1 - \tau_2)^2 - 4\tau_1 \tau_2 K_c K_p}}{2\tau_1 \tau_2}$$

From this, you can make the following observations:

- When $K_c = 0$, then:

$$p_1, p_2 = \frac{-(\tau_1 + \tau_2) \pm \sqrt{(\tau_1 - \tau_2)^2}}{2\tau_1\tau_2} = \frac{-(\tau_1 + \tau_2) \pm (\tau_1 - \tau_2)}{2\tau_1\tau_2} = -\frac{1}{\tau_1}, -\frac{1}{\tau_2}$$

the “standard” roots for a non-interacting series of processes.

- We can get a critically damped response when the roots are repeated, or when:

$$(\tau_1 - \tau_2)^2 - 4\tau_1\tau_2K_cK_p = 0 \Rightarrow K_c = \frac{(\tau_1 - \tau_2)^2}{4\tau_1\tau_2K_p}$$

So, this means that the system will be overdamped when:

$$(\tau_1 - \tau_2)^2 - 4\tau_1\tau_2K_cK_p > 0 \Rightarrow K_c < \frac{(\tau_1 - \tau_2)^2}{4\tau_1\tau_2K_p}$$

Furthermore, for these values of K_c the poles will remain negative real.

- We can get an underdamped response when:

$$(\tau_1 - \tau_2)^2 - 4\tau_1\tau_2K_cK_p < 0 \Rightarrow K_c > \frac{(\tau_1 - \tau_2)^2}{4\tau_1\tau_2K_p}$$

The poles are then given by:

$$p_1, p_2 = -\frac{\tau_1 + \tau_2}{2\tau_1\tau_2} \pm i \frac{\sqrt{4\tau_1\tau_2K_cK_p - (\tau_1 - \tau_2)^2}}{2\tau_1\tau_2}$$

The real portion of these roots remain negative, whereas the imaginary part gets bigger and bigger as K_c increases.

These types of plots are more instructive for more complicated systems — for example, see the plot on page 265 of SEM. This plot shows that as K_c increases, an underdamped system results. However, the real portion of the complex conjugate roots also increases, going positive at $K_c > 30$. So, the gain must be kept below this value.