



Why Color Management?

James C. King

A Principal Scientist

Advanced Technology Group (ATG)

Adobe Systems Incorporated

everywhere
you
look™



Outline

- **Introduction to Color Management**
- **Basics of Conversions**
- **Color workflow issues**
- **Conversion Glitches**
 - **Where do things go wrong?**
- **A user's perspective -- Some thoughts on a better way**



Introduction to Color Management

Just the basics



The Root Issue

Devices Do Color Differently

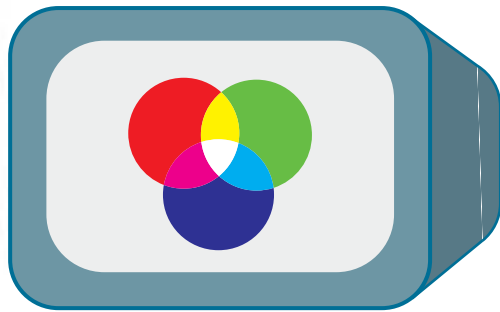

Display 1



Display 2

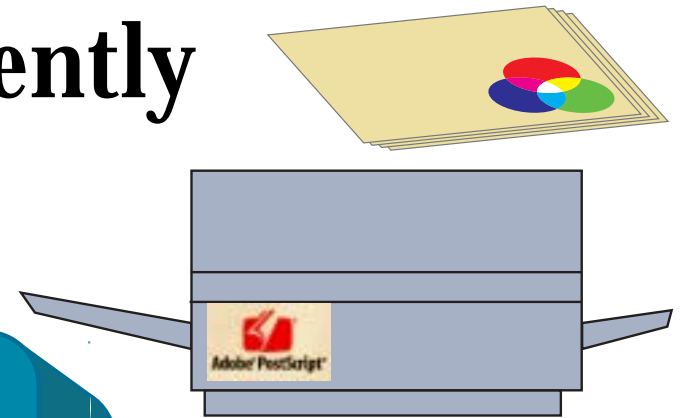

Printer

Consistency

Same results require different values

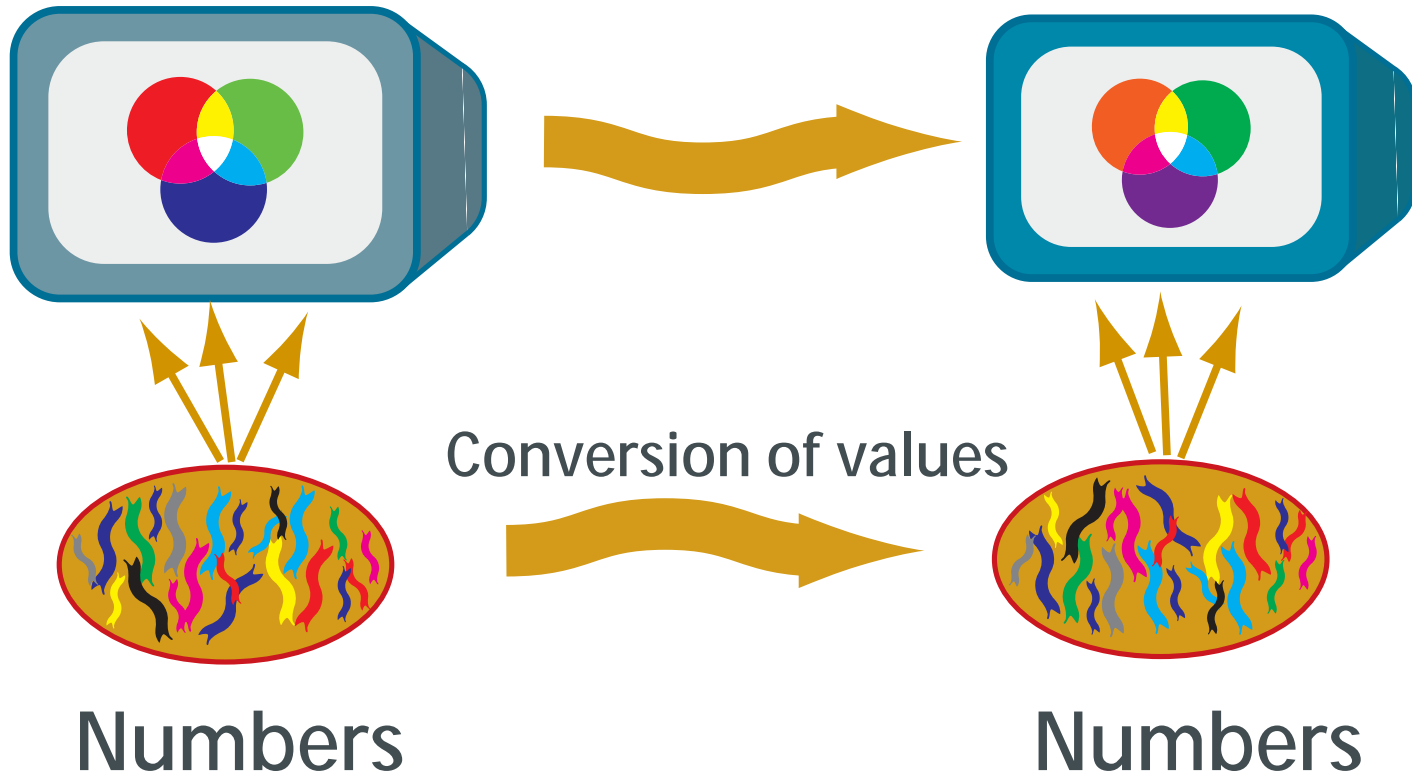

Consistency

- **Same values produce different colors**
- **Same colors require different values**

Color Value Conversions

- **Transform:**
 - *Table and interpolations*
 - *Device model formulae*



The n by m Problem

- $(n \times m)$ Transforms required
 - *Both source and destination must be known for each*

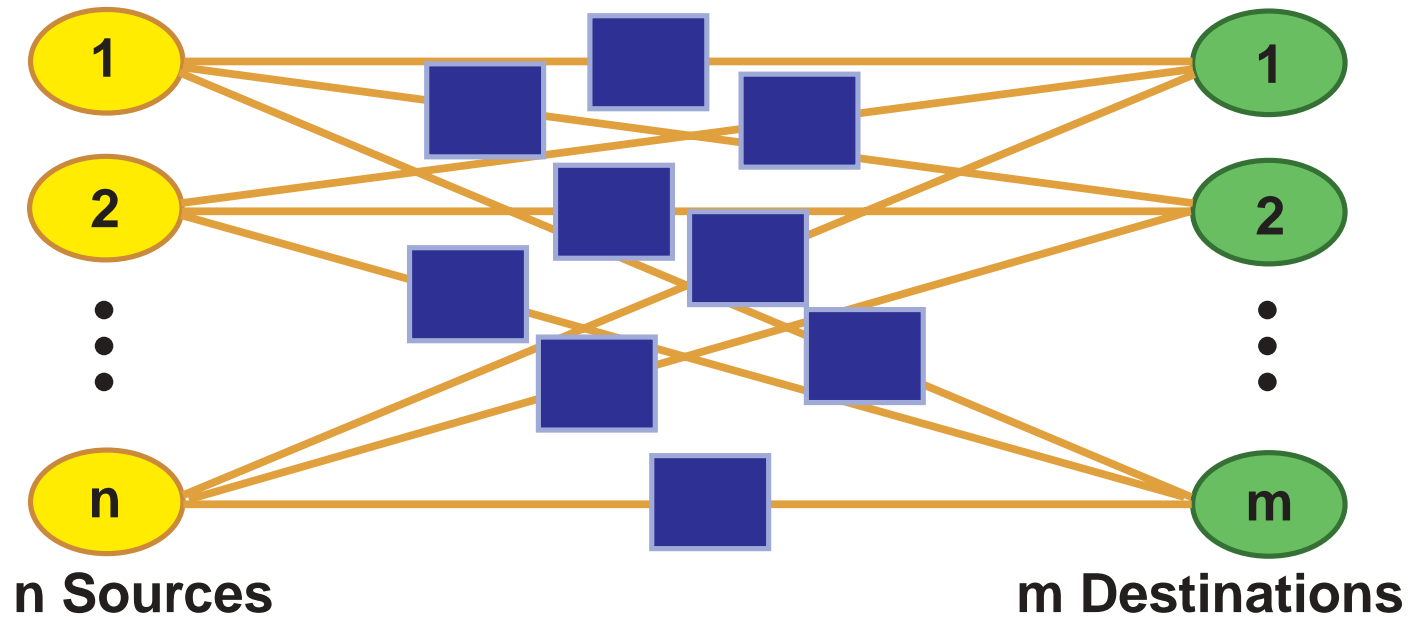

Device Independence

- $(n + m)$ not $(n \times m)$ Transforms
 - *Each source and destination handled independently*

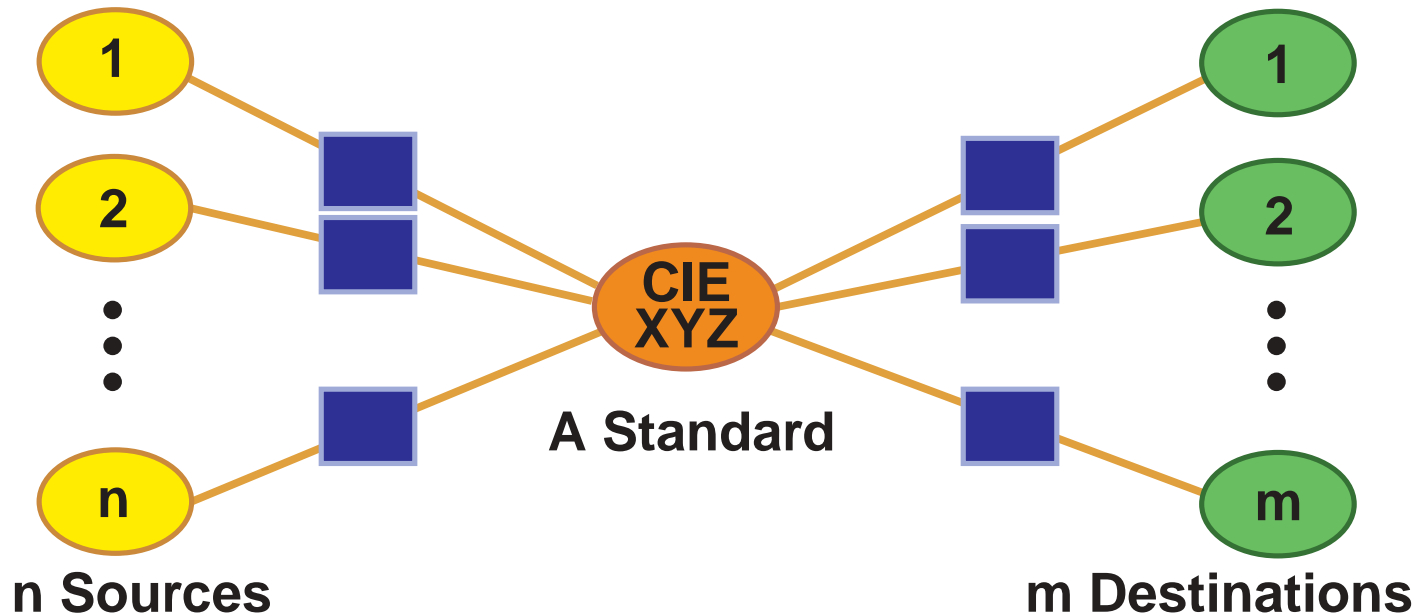

Basic ICC Diagram (International Color Consortium)

- Composite conversion “compiled”
- ICC Profiles define colorspaces

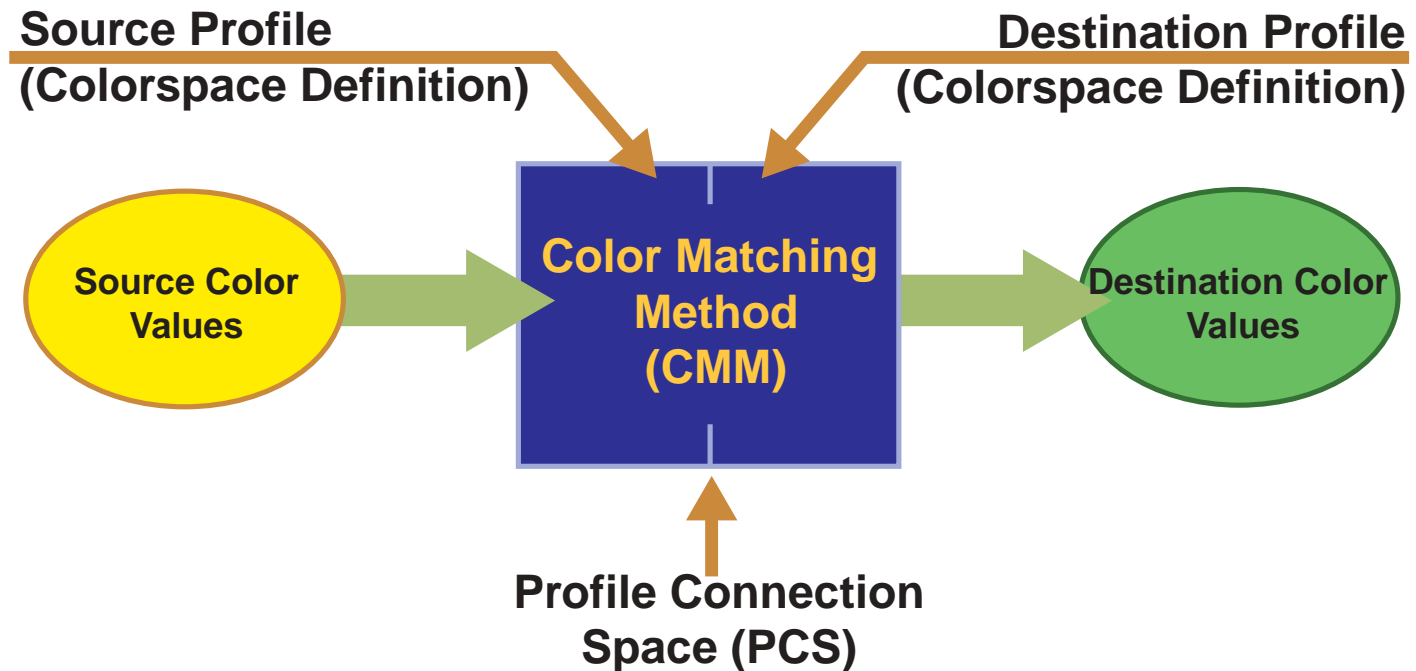

Photoshop: Basic Workflow

- Monitor profile supplied by system
- Workspace profile set by user

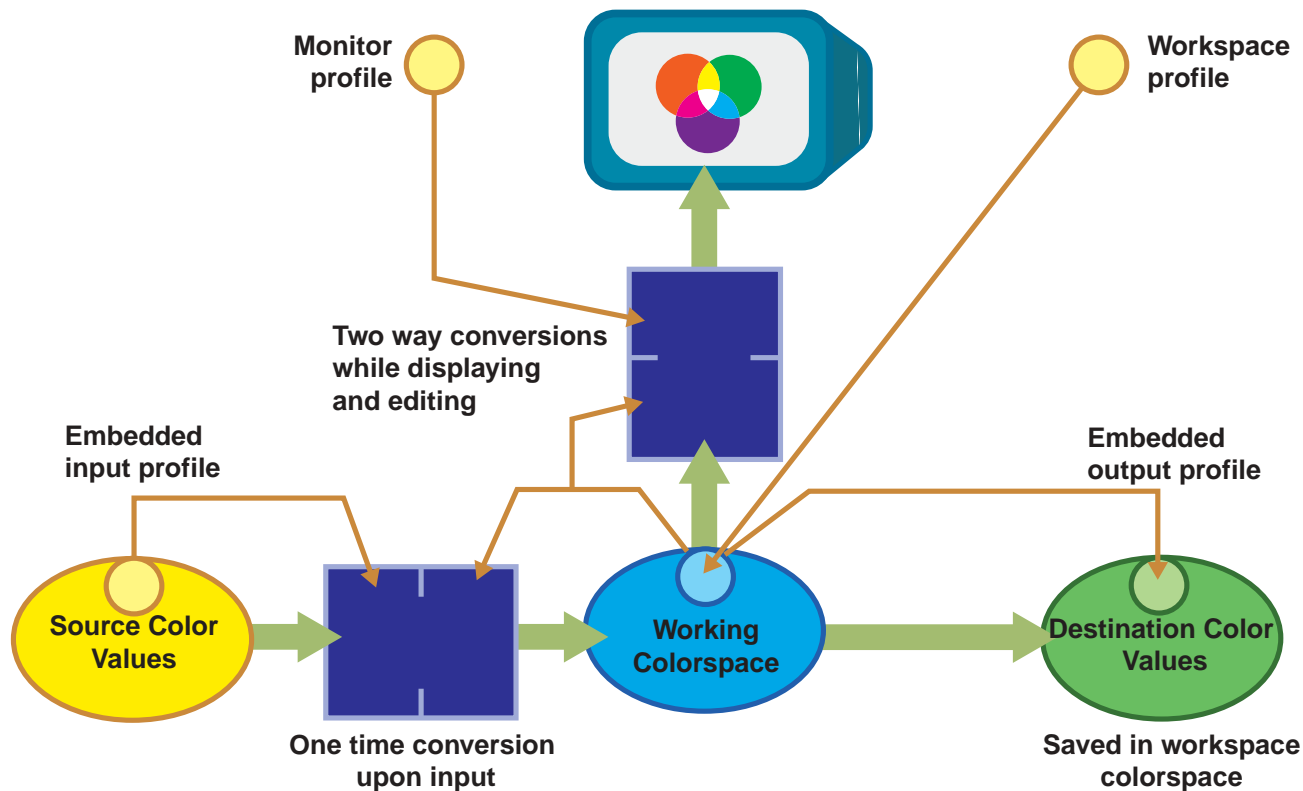

Rendering Intents

- “gamut mapping”
 - *Destination colorspace “smaller” than source colorspace*
 - *Shrinking the range of colors in an object*

Gamut Differences

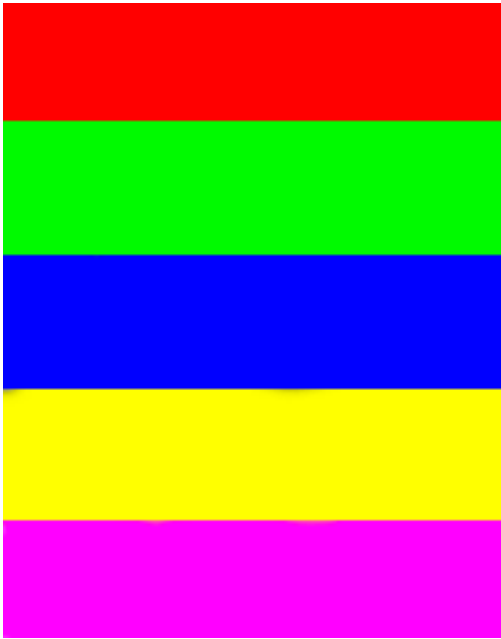

RGB
(Original)



CMYK
(Photoshop Swop Coated)

Gamut Mapping

- **Four situations identified**
 - *Perceptual (pictures)*
 - *Saturated (graphics)*
 - *Relative Colorimetric (logos)*
 - *Absolute Colorimetric (strict conversions)*

Rendering Requirements

Logo-Colorimetric



Newsletter

[Placeholder text for the left column of the newsletter]



Picture-Perceptual

Graph-Saturated

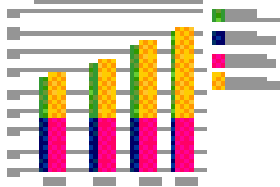

Rendering Intents

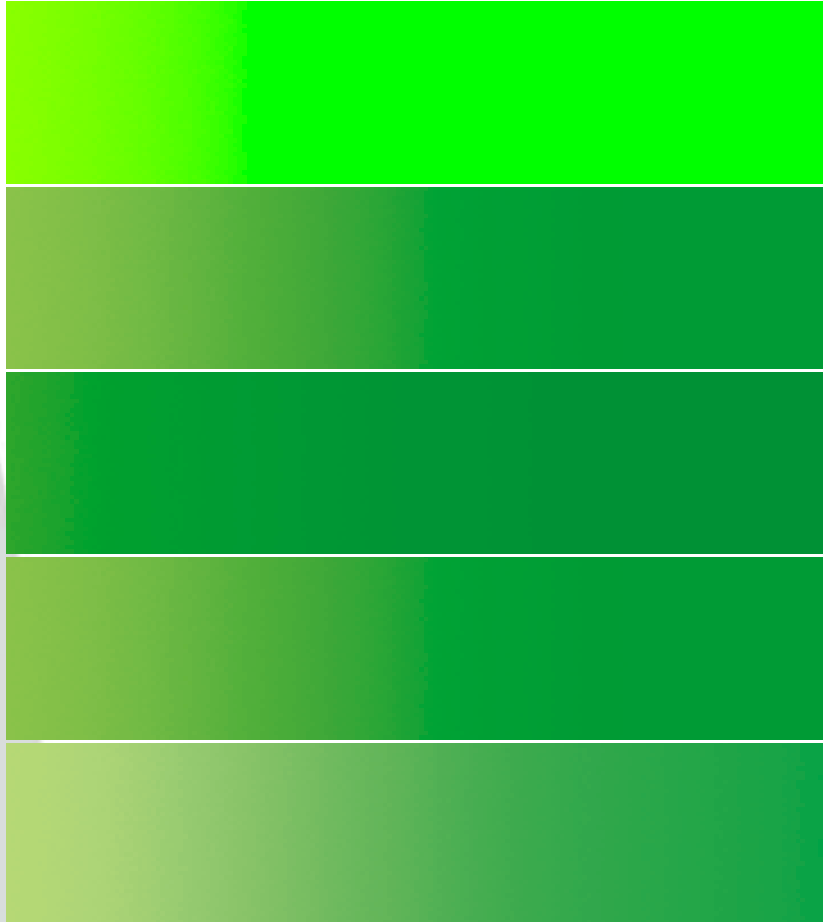

RGB Original

CMYK-Perceptual

CMYK-Saturated

CMYK-Relative Colorimetric

CMYK-Absolute Colorimetric

Rendering Intents

- Intent is property of the source
- Action happens during output

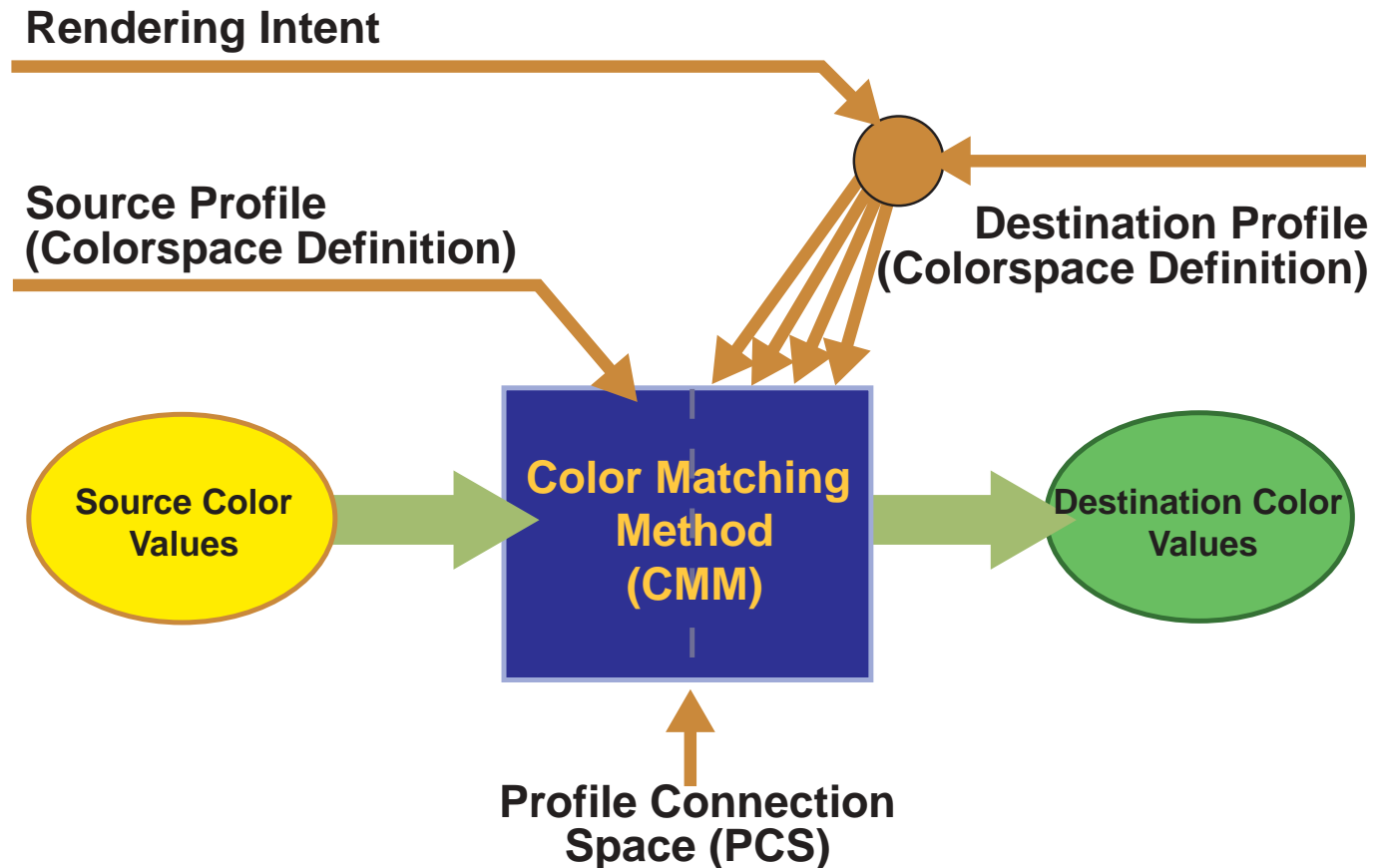

Rendering Intents

- Monitor profile supplied by system
- Workspace profile set by user

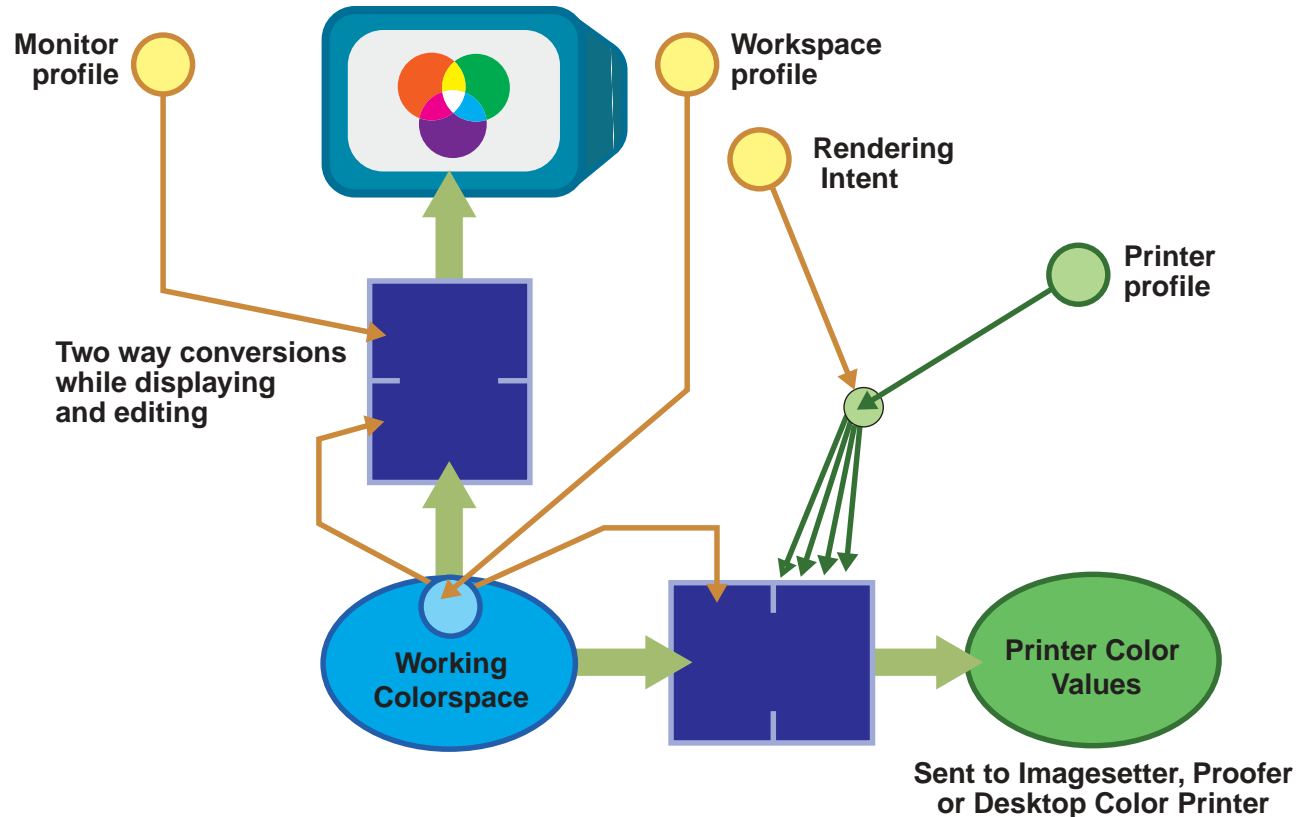

Sent to Imagesetter, Proofer
or Desktop Color Printer

Soft Proofing

- What would it look like on my printer

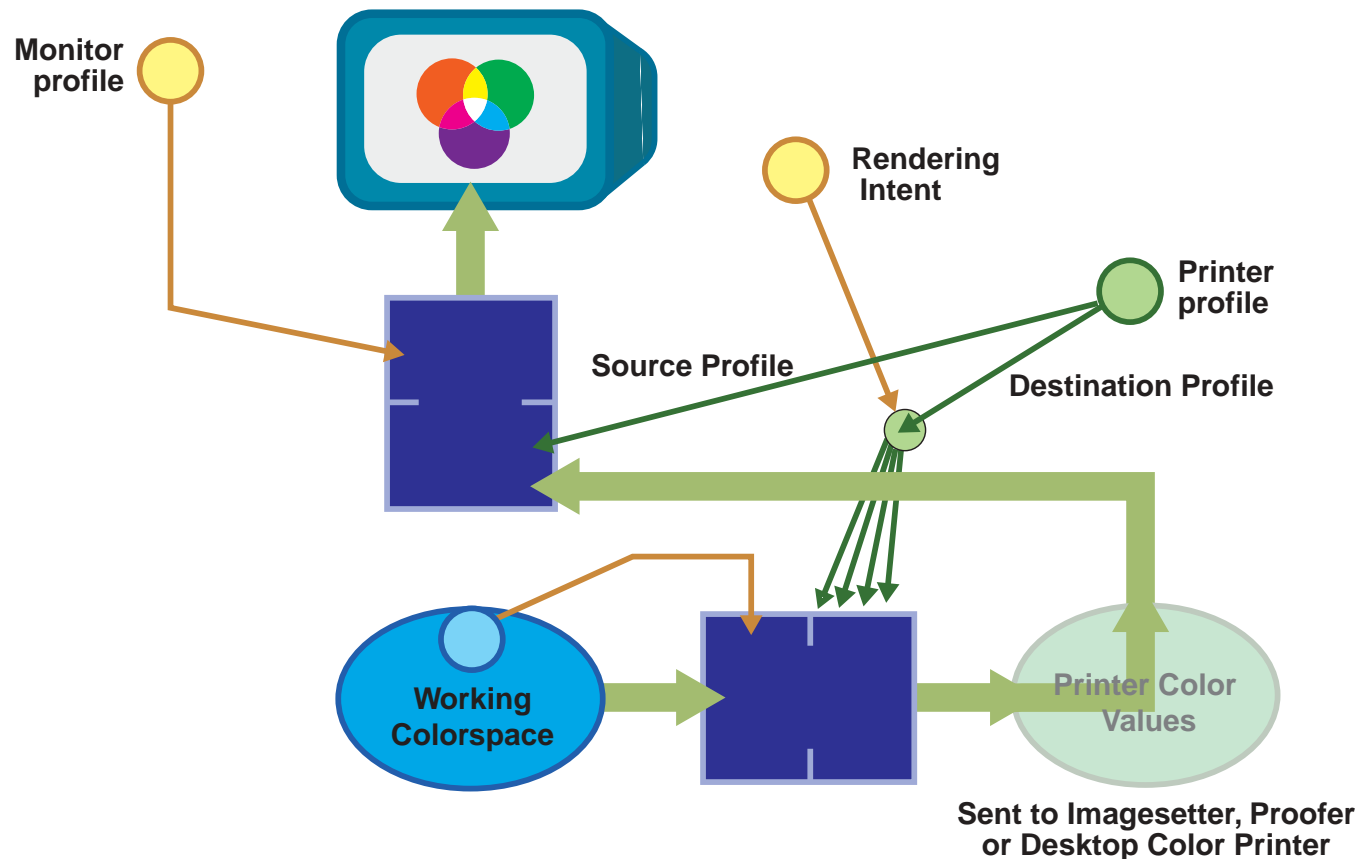

Sent to Imagesetter, Proofer
or Desktop Color Printer

Basics of Conversions



Device Models

- e.g., CRT Displays

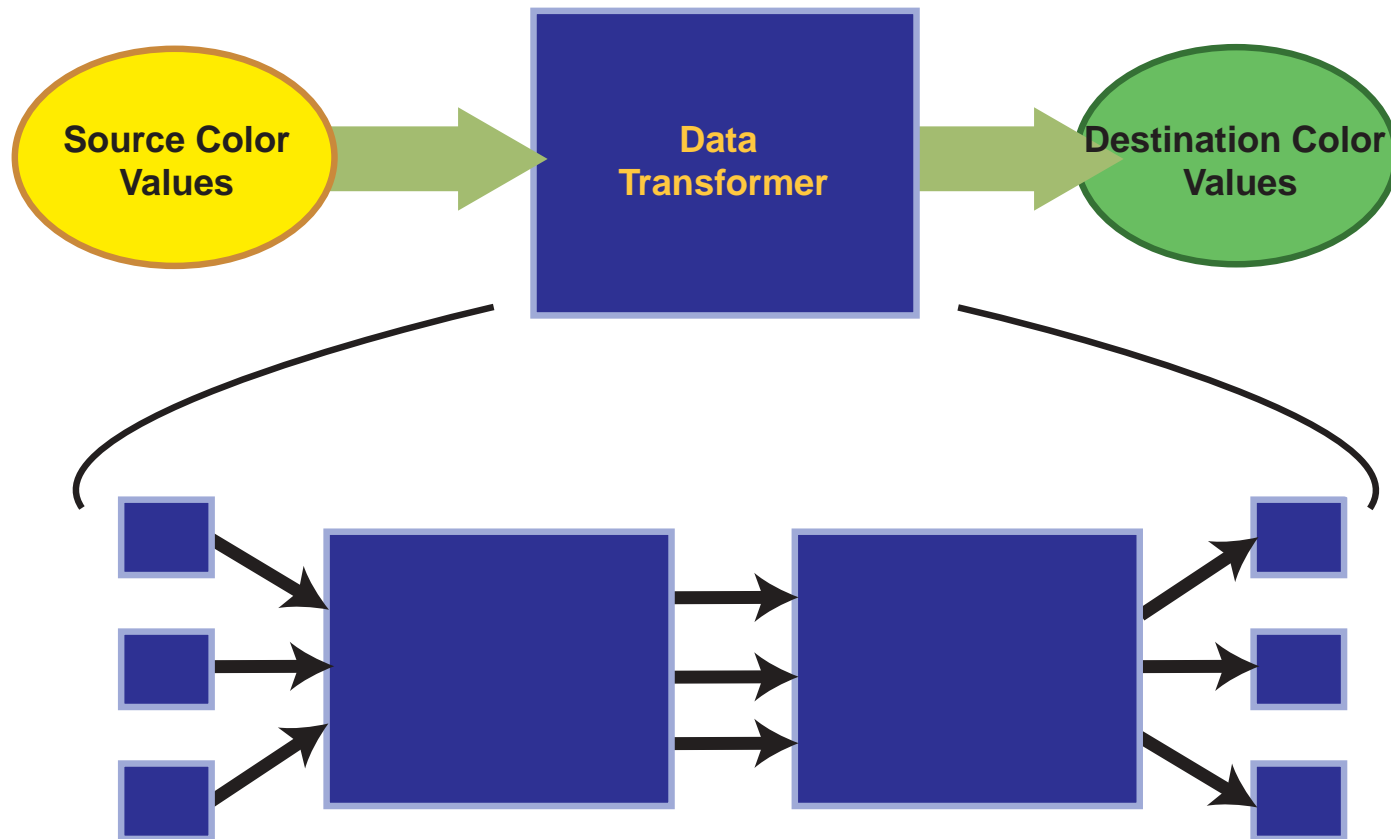

Device Models (CRTs)

- Linear Additive Devices

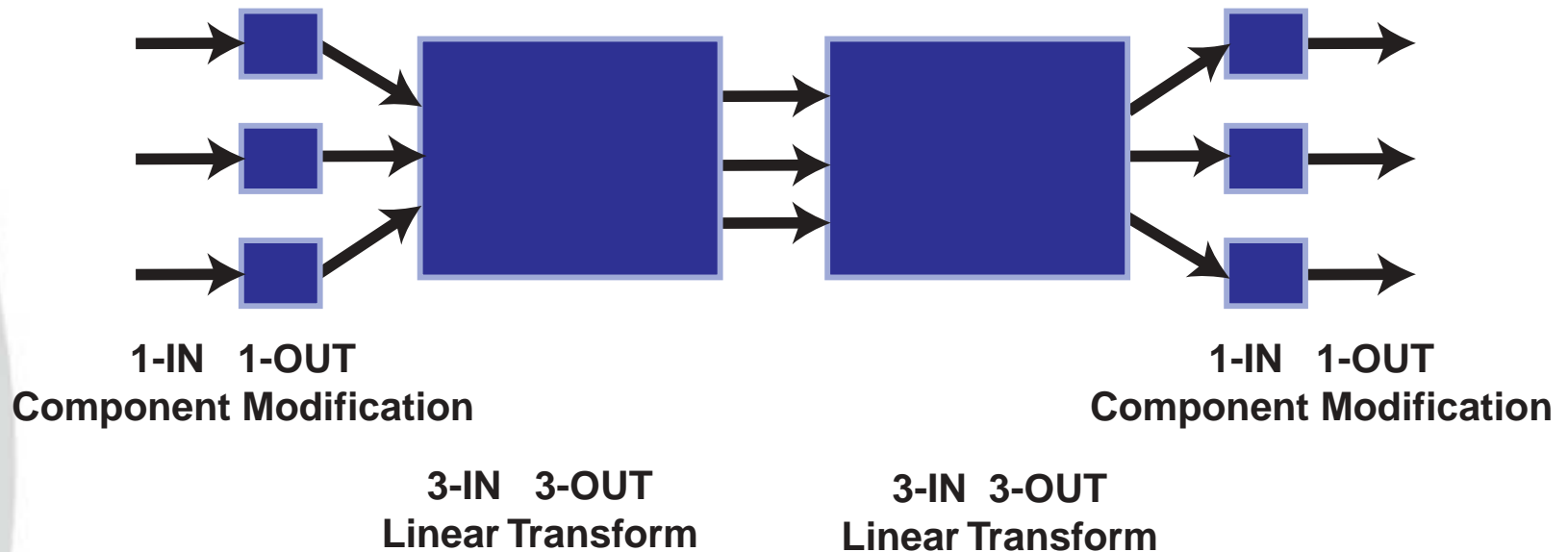

Single Component

- Things like Gamma adjustments
- “Linearize” the components

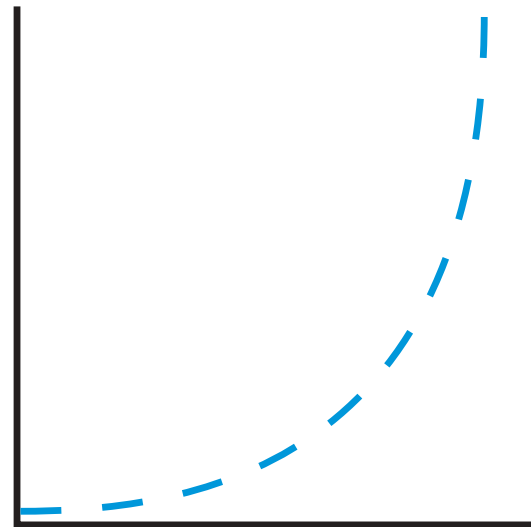
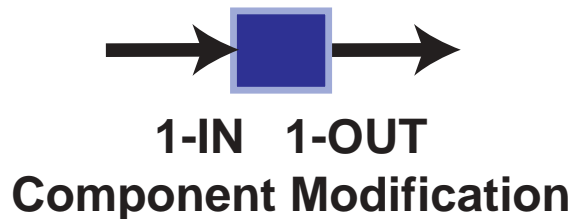

The Famous 3x3

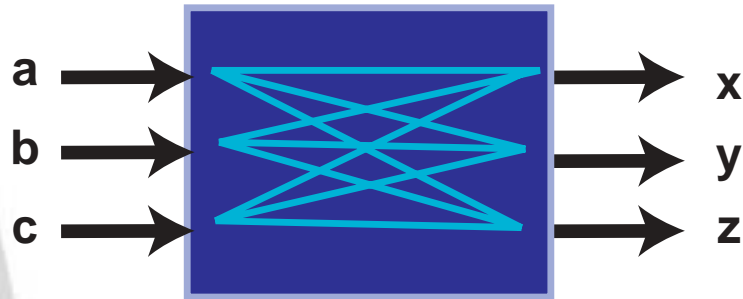

**3-IN 3-OUT
Linear Transform**

$$x = 1.0 \cdot a + 1.4 \cdot b + 0.8 \cdot c$$

$$y = 0.0 \cdot a + 2.5 \cdot b + 0.6 \cdot c$$

$$z = 1.3 \cdot a + 1.4 \cdot b + 1.3 \cdot c$$

$$\begin{pmatrix} 1.0 & 1.4 & 0.8 \\ 0.0 & 2.5 & 0.6 \\ 1.3 & 1.4 & 1.3 \end{pmatrix}$$

3 x 3 Matrix

Device Models (CRTs)

- **Linear Additive Devices**

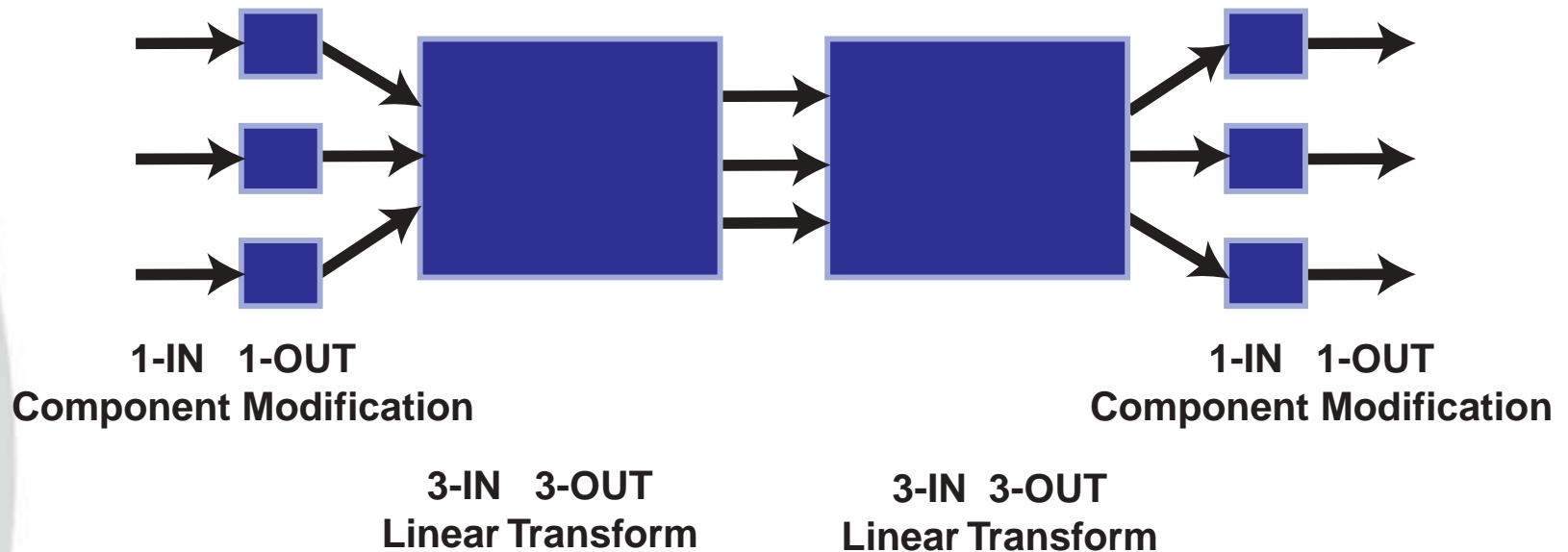
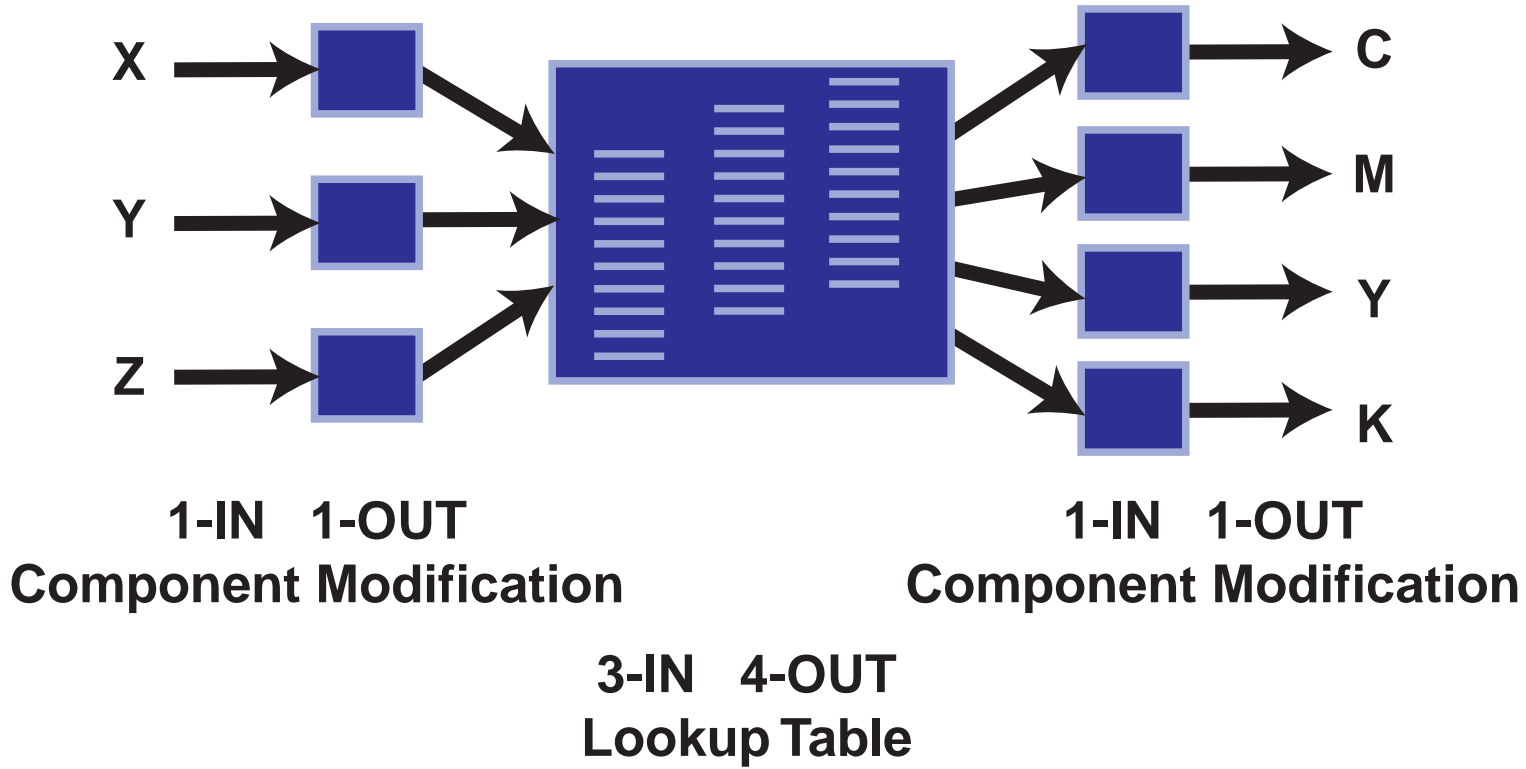
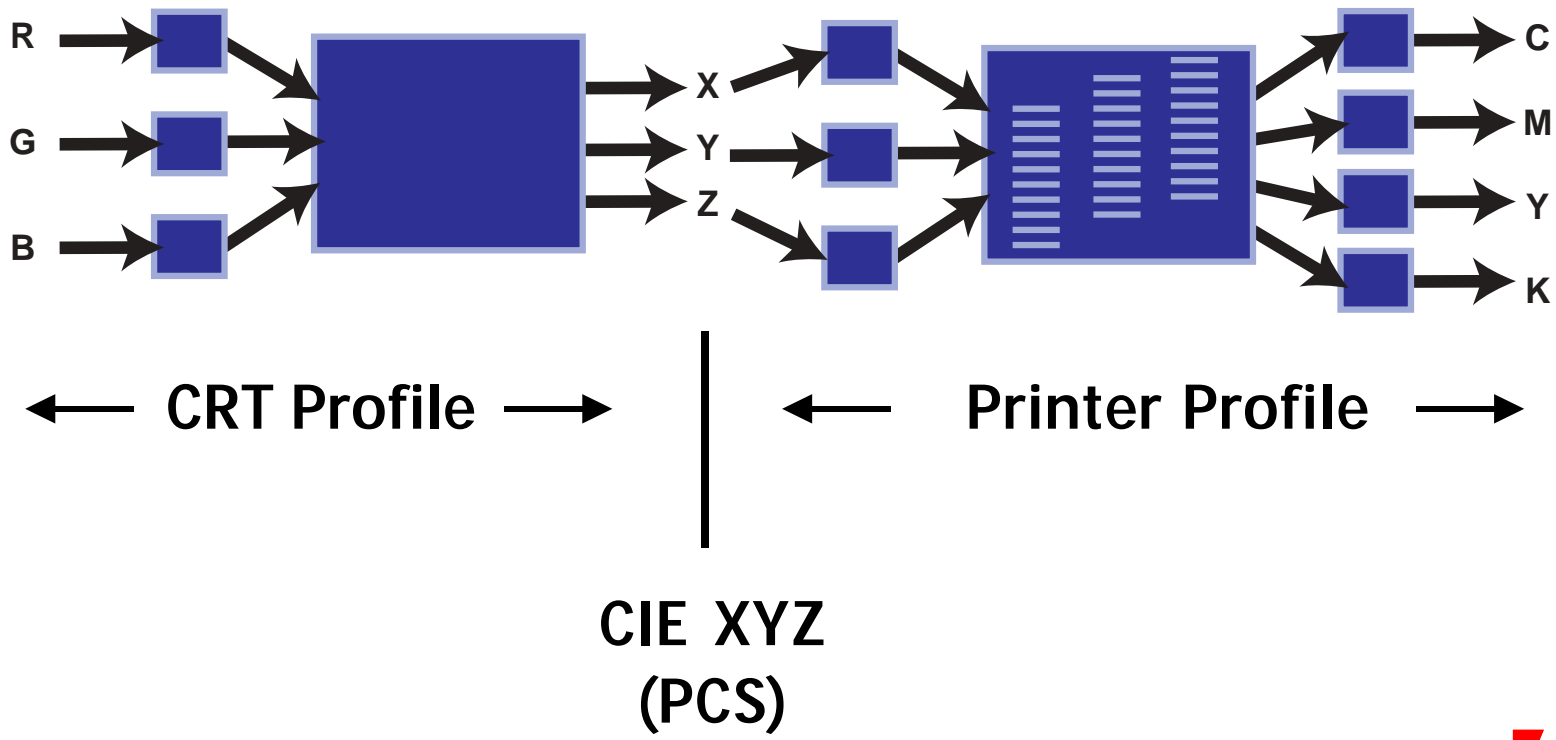

Table Lookup

- E.g., Printers



CRT to Printer



White & Black Points

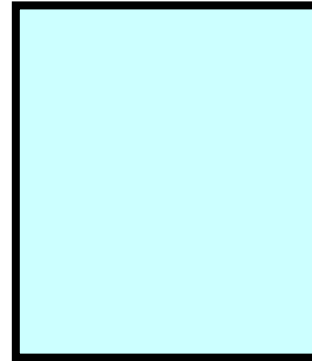
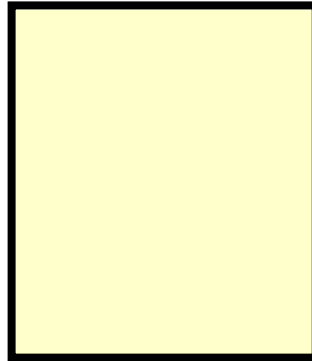
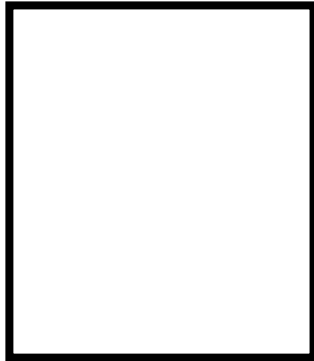



Color Workflow Issues



Both PostScript and PDF have what it takes

- **PostScript**

- *Color Space Arrays (CSA) -- source profiles*
- *Color Rendering Dictionaries (CRD) -- destination profiles*
- *No direct support for ICC profiles but converters available*

- **PDF**

- *Color Space Resources (CSR) -- source profiles*
- *No destination profiles*
- *Supports ICC profiles as option in addition to PostScript like source profiles*

- **Both support**

- *Intents*
- *Compound documents -- multiple colorspaces per page/document*

Real Example

Hello World

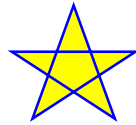

Star -- **filled** with L*a*b* Yellow /// Star -- **stroked** with Calibrated RGB Blue

```
%PDF-1.2
1 0 obj
<<
  /Type /Page
  /Parent 5 0 R
  /Resources 3 0 R
  /Contents 2 0 R
>>
endobj
```

```
2 0 obj
<< /Length 51 >>
stream
  BT
  /F1 24 Tf
  1 0 0 1 260 600 Tm
  /CS1 cs
  63 127 127 sc
  (Hello World)Tj
  ET

  100 0 127 sc

  /CS2 CS
  0 0 1 SC
  315 572 m
  299 528 l
  339 554 l
  291 554 l
  331 528 l
  b
endstream
endobj
```

```
3 0 obj
<</ProcSet[/PDF/Text]
/Font <</F1 4 0 R>>
/ColorSpace
  <</CS1
  [ /Lab << /Range
  [-128 127 -128 127]
  /WhitePoint
  [ 0.951 1 1.089]
  >> ] >>
  <</CS2
  [ /CalRGB <<
  /Gamma
  [2.222 2.222 2.222]
  /Matrix
  [0.412 0.213 0.019
  0.358 0.715 0.119
  0.181 0.072 0.951]
  /WhitePoint
  [0.951 1 1.089]
  >> ] >>
>>
endobj
```

Star -- **filled** with L*a*b* Yellow /// Star -- **stroked** with Calibrated RGB Blue

```
4 0 obj
<<
  /Type /Font
  /Subtype /Type1
  /Name /F1
  /BaseFont/Helvetica
>>
endobj

5 0 obj
<<
  /Type /Pages
  /Kids [ 1 0 R ]
  /Count 1
  /MediaBox
    [ 0 0 612 792 ] >>
endobj
```

```
6 0 obj
<<
  /Type /Catalog
  /Pages 5 0 R
>>
endobj

trailer
<<
  /Root 6 0 R
>>
```

Star -- **filled** with L*a*b* Yellow /// Star -- **stroked** with Calibrated RGB Blue

```
%PDF-1.2
1 0 obj
<<
  /Type /Page
  /Parent 5 0 R
  /Resources 3 0 R
  /Contents 2 0 R
>>
endobj
```

```
2 0 obj
<< /Length 51 >>
stream
  BT
  /F1 24 Tf
  1 0 0 1 260 600 Tm
  /CS1 cs
  63 127 127 sc
  (Hello World)Tj
  ET

  100 0 127 sc

  /CS2 CS
  0 0 1 SC
  315 572 m
  299 528 l
  339 554 l
  291 554 l
  331 528 l
  b
endstream
endobj
```

```
3 0 obj
<</ProcSet[/PDF/Text]/
Font <</F1 4 0 R>>
/ColorSpace
<</CS1
  [ /Lab << /Range
  [-128 127 -128 127]
  /WhitePoint
  [ 0.951 1 1.089]
  >> ] >>
<</CS2
  [/ICCBased 7 0 obj]
>>
>>
endobj

7 0 obj
<</Length 345
  /N 3 >>
stream
... (ICC Profile) ...
endstream
endobj
```

A PostScript File Equivalent to Example 8

<pre> %!PS % PostScript file that generates same output as example 08 /Helvetica findfont 24 scalefont setfont 260 600 moveto [/CIEBasedABC << /RangeABC [0 100 -128 127 -128 127] /DecodeABC [{16 add 116 div} bind {500 div} bind {200 div} bind] /MatrixABC [1 1 1 1 0 0 0 0 -1] /DecodeLMN [{dup 6 29 div ge {dup dup mul mul} </pre>	<pre> {4 29 div sub 108 841 div mul} ifelse 0.9505 mul} bind {dup 6 29 div ge {dup dup mul mul} {4 29 div sub 108 841 div mul} ifelse} bind {dup 6 29 div ge {dup dup mul mul} {4 29 div sub 108 841 div mul} ifelse 1.0890 mul} bind] /WhitePoint [0.9505 1 1.0890] >>] setcolorspace 63 127 127 setcolor (Hello World) show </pre>	<pre> 100 0 127 setcolor 315 572 moveto 299 528 lineto 339 554 lineto 291 554 lineto 331 528 lineto gsave fill grestore [/CIEBasedABC << /DecodeLMN [{1 0.45 div exp} bind dup dup] /MatrixLMN [0.412 0.213 0.019 0.358 0.715 0.119 0.181 0.072 0.951] /WhitePoint [0.9505 1 1.0890] >>] setcolorspace 0 0 1 setcolor </pre>
--	--	---

A PostScript File Equivalent to Example 8

```
closepath  
true setstrokeadjust  
stroke  
  
showpage
```



Conversion Glitches

Where do things go wrong?



Limited Places for Error

- **Quantization (truncation)**
- **Gamut compression**
- **White Point/Black Point Compensation**
- **Bad arithmetic**
- **Interpolation errors**

Quantization

- **8-bits isn't really enough**
 - *No room for mistakes*
 - *Some colorspace not spaced right*
- **Move to 16-bits per component**
 - *It only doubles color value sizes*

Gamut compression

- **Avoid it**
- **Delay it**
- **Do it only once at the end**

White Point/Black Point

- **ICC Specification hasn't been clear**
- **Change ICC model**
 - *To be more like PostScript*

Bad arithmetic

- Don't do it
- Get help

Interpolation errors

- Adjust table size for more accuracy
- Tables need fractional values
 - *Get ICC to change*



Compound Documents

It gets complicated!



Compound Documents (more than one colorspace)

- Photoshop

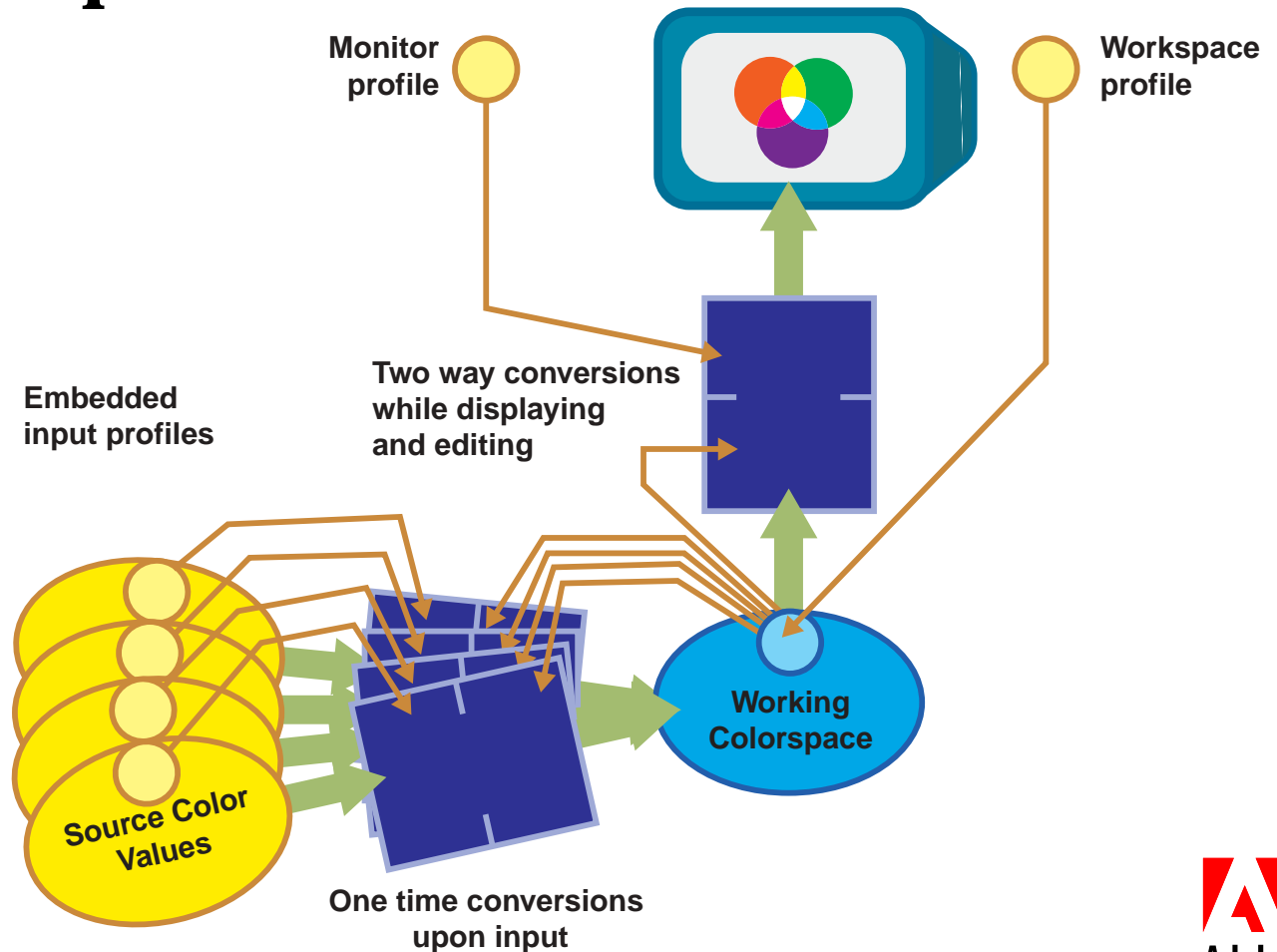

Compound Documents (more than one colorspace)

- PageMaker

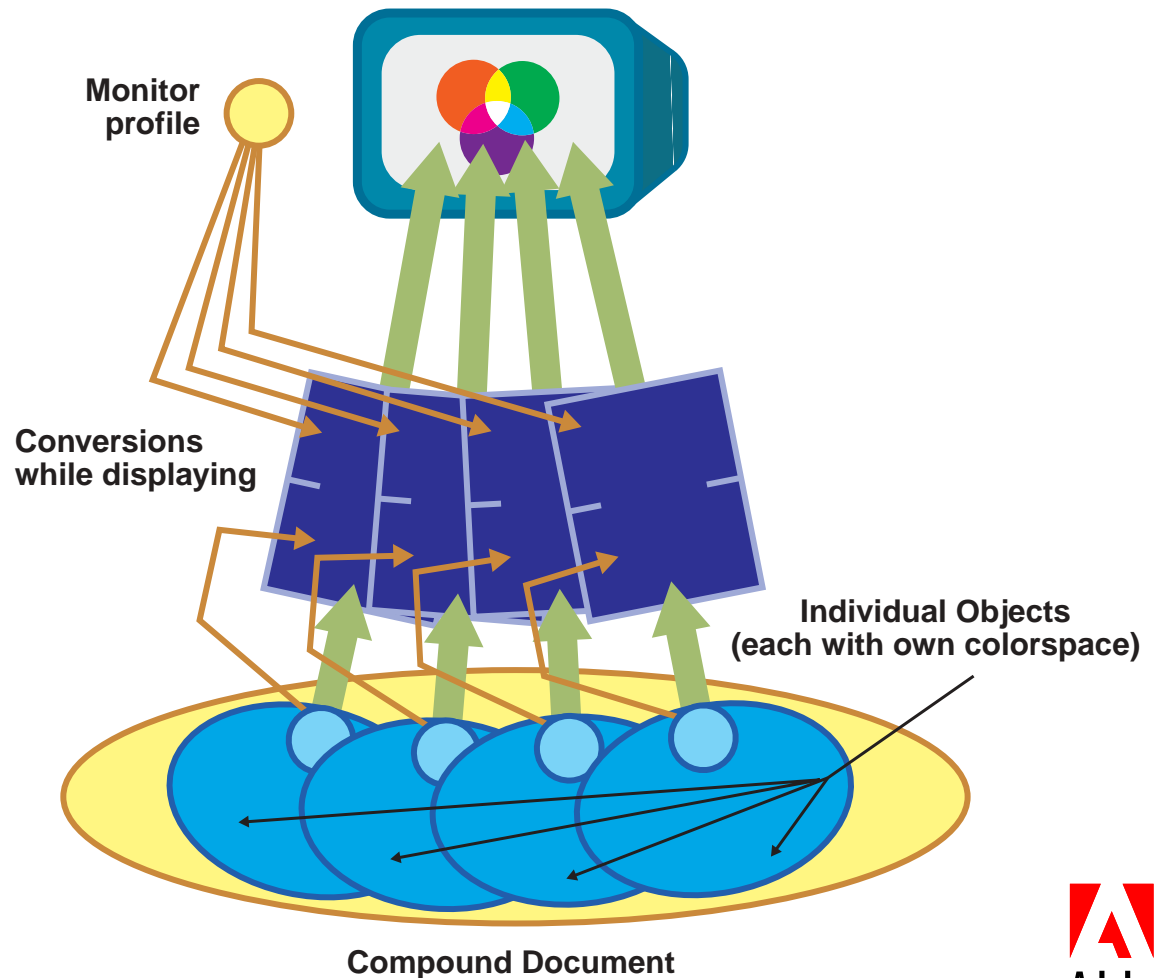

Compound Documents (more than one colorspace)

- PageMaker or In the RIP

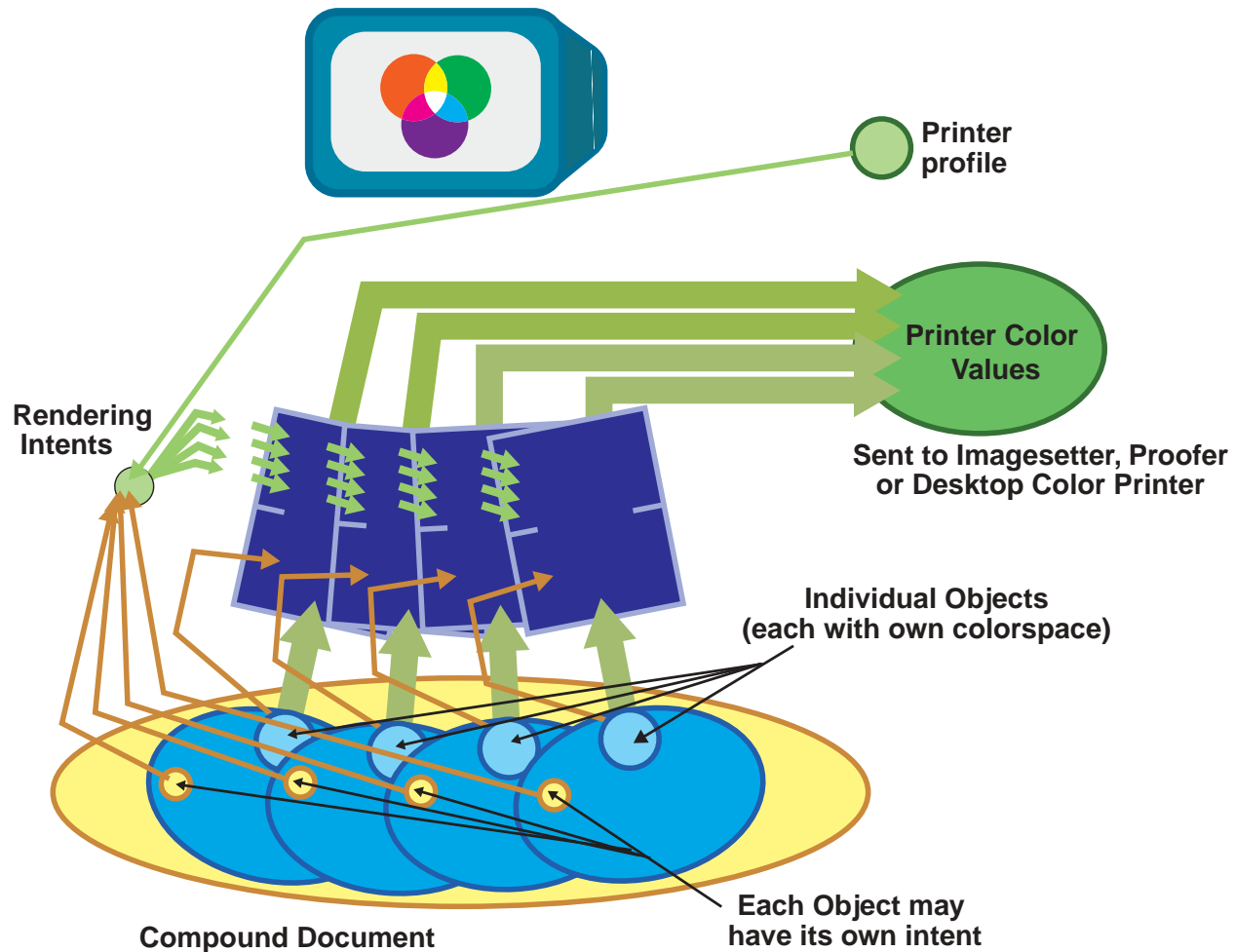



A User's View

**And some thoughts
on a better model**



A User's View

- What does a user want?
 - *This red color*
 - *What is a colorspace?*
 - *Why do I care?*
- Users don't ask for:
 - *a monitor colorspace*
 - *an ICC profile*
- They just want this **red**

Now is Device Centric

- We move colors through device colorspaces

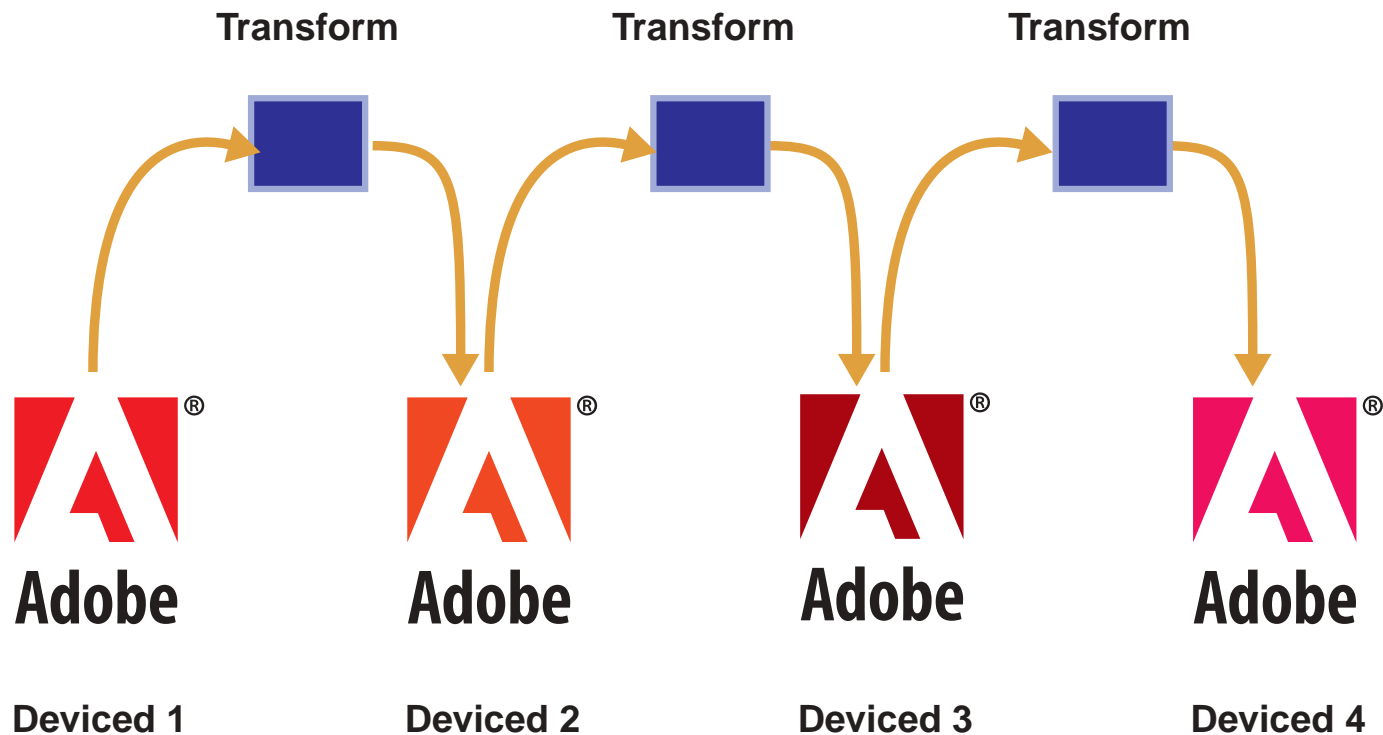

We have it backwards!

- **Should A slide over B**
- **Or should B slide under A**

Fixed Colored Data

Just have Windows onto it

- Only Change the view of it

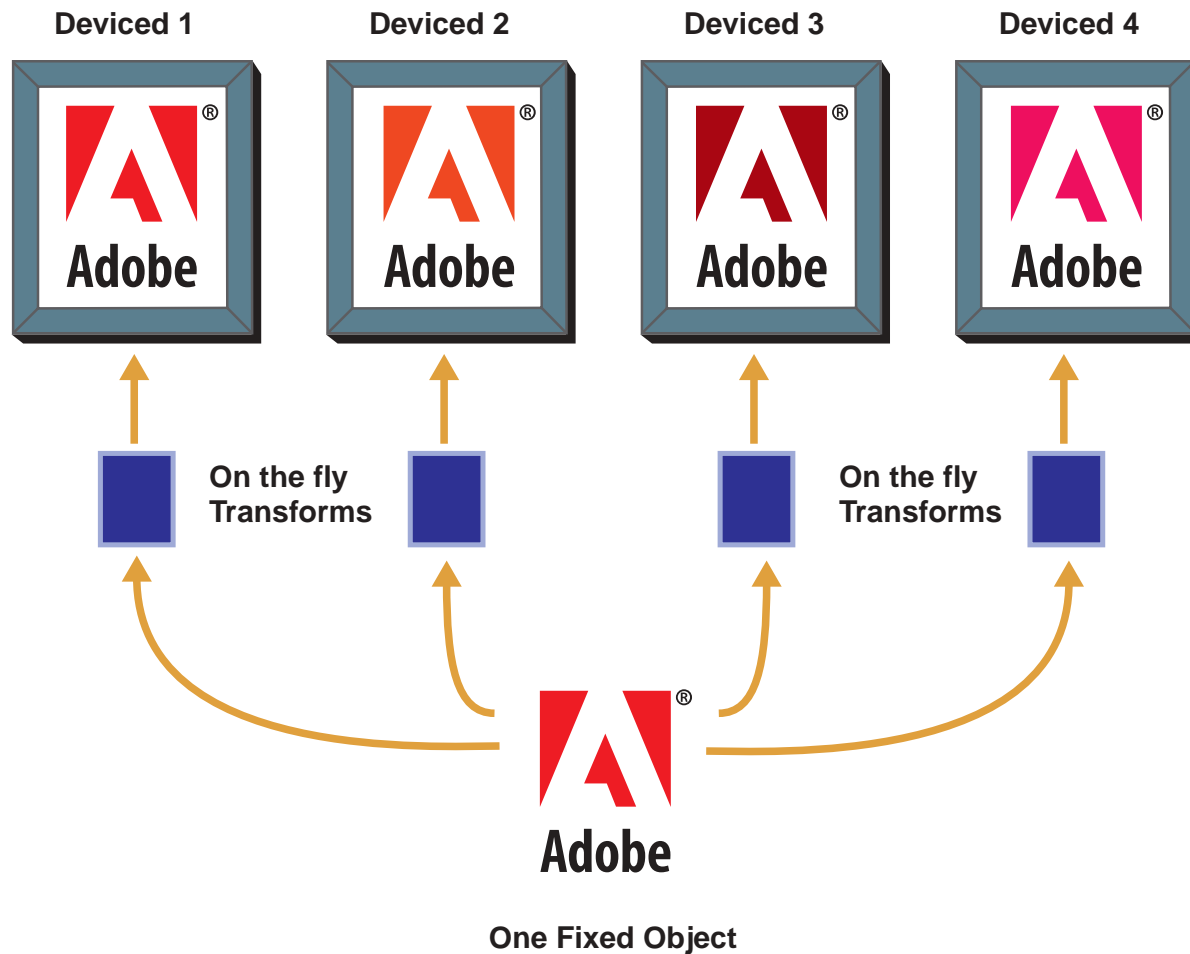

Fixed Colored Data

- **A universal colorspace**
 - *Extend the idea of workspace*
- **All colors visible by humans**
- **Enough bits to allow flexibility**
 - *Precision*
 - *Range*

Homework

- How do you edit using this model?

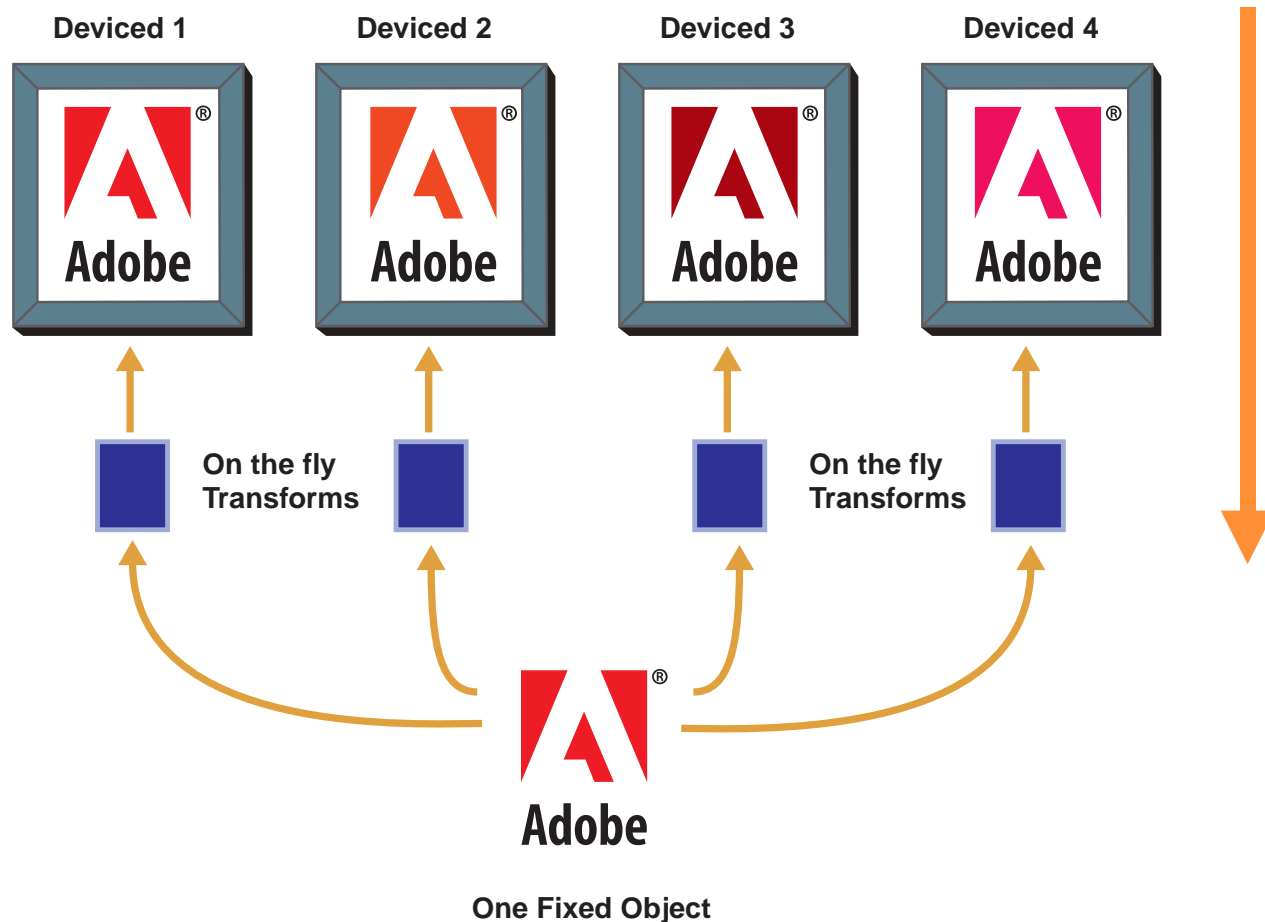

everywhere you look



Adobe

