

2x6 Antenna Switch Controller

* Only one radio port selectable per antenna. The first one to have the antenna keeps it until released.

* Can use rotary, toggle, or latched push button switches. Latched push button or toggle allow for multiple antennas per radio port (for stacking). The inputs are +12V active high logic and float when not selected. You might consider a 7 position rotary switch if also using the BCD inputs. This will allow for a "no select" position for the rig or computer to control the selections.

* Along with manual switching you can use BCD band data from your radio or logging program. The decoding follows the "standard" of NA, TRLog, and others. To wire the six contest band just short across from J15/J16 to the corresponding switch connections. You can also "wire OR" bands to one port. For example to put a tri-bander on Port5 you can connect the 10, 15, and 20m decoded outputs to the port 5 switch position. The inputs are optically isolated and convert from 5V or 12V active high logic to relay (12V) levels.

* CMOS devices (4028, 4011) take +12V VCC directly.

* Quad optoisolators convert external 5V/12V interface to +12V.

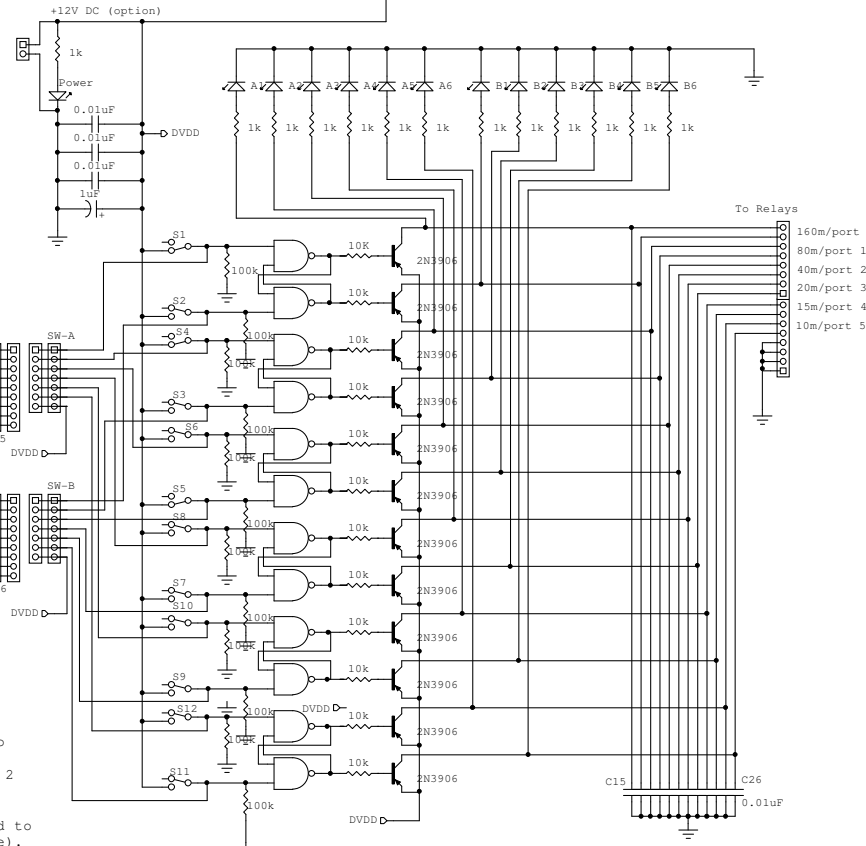
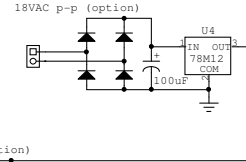

NOTE: The switch settings show :
 Radio A connected to both antenna 1 (S1 active) and antenna 2 (S4 active).
 Radio B is connected to antenna 3 (S5 active).

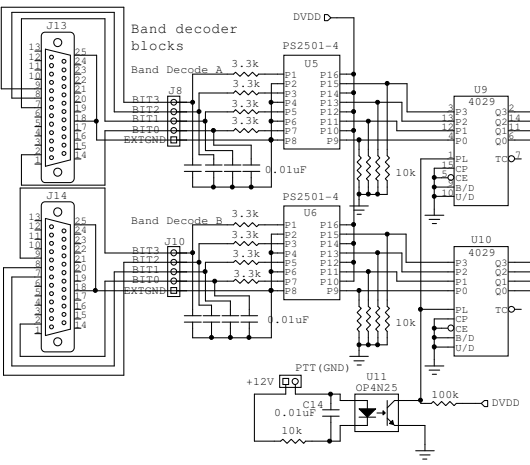

Ronald D. Rossi, KK1L	
2x6 Antenna Switch Controller Dual Band Decoder	
Rev 4.7	ID 2x6 Antenna Switch Contoller
Date: 28 February 2006	Page: 1 of 1