

DUKE ENERGY AND SUBSIDIARY COMPANIES
CORRUGATED STAINLESS STEEL TUBING (CSST)

1. GENERAL

In the interest of safe and reliable service, Duke Energy has adopted these requirements for the installation, operation, and maintenance of Corrugated Stainless Steel Tubing (CSST) house piping. House piping consists of pipe and fittings from the outlet of the meter to the equipment shutoff valve. If any provision herein conflicts with any local, state or federal ordinance, rule or regulation, the latter shall govern in the area in which the installation is made.

The *National Fuel Gas Code* ANSI Z223.1 NFPA 54, is an integral part of these requirements. This code covers gas piping from the outlet of the gas meter to the inlet of the gas appliance, including appliance installations. Duke Energy requirements replace *National Fuel Gas Code* requirements when they differ.

Certain local governments have the responsibility for house piping inspections and testing. Please contact the local building department for installation requirements. In these instances, Duke Energy requires an approved house piping inspection & pressure test performed by the local inspection department before turning on a meter.

Qualified personnel shall install house piping at customer's expense. Customer is responsible for the installation and maintenance of the house piping and assumes all risk resulting from defects therein.

2. IMPORTANT TELEPHONE NUMBERS

Duke Energy Gas & Electric Services

For information regarding installation specifications.

Call	(513) 651-0444
Toll Free	1-800-262-3000 Extension 3866

To Report Gas Trouble

Call	(513) 651-4466
Toll Free	1-800-634-4300

For All Inspections and Meter Sets

All gas meter sets, applications, inspections, and to inquire on status of existing requests for these services, call Duke Energy Gas & Electric Services (513) 651-0444
 Toll Free 1-800-262-3000 Extension 3866

For Locations of any Underground Utility

Call Before You Dig – Ohio	1-800-362-2764
Call Before You Dig – Kentucky	1-800-752-6007
Call Before You Dig – Indiana	1-800-382-5544

Call the Utilities Protection Service at least two (2) working days in advance.

3. CSST GAS PIPING SYSTEM DESIGN

3.1 Sizing

The qualified installer is responsible for sizing CSST installations in accordance with the manufacturer's installation requirements. Duke Energy does not size or verify the size of CSST installations. Meter outlet to building wall piping shall be 1" size steel or larger. Other steel piping sections such as manifolds and sediment traps shall be ½" size or larger.

3.2 Delivery Pressure

Standard delivery pressure is approximately 7 inches water column at the meter. An optional elevated delivery pressure of 2 psig is approved for CSST systems where available. Contact Duke Energy to verify elevated pressure availability prior to sizing and installing a 2 psig system.

3.3 System Configuration

Typical standard pressure CSST configurations are shown in Exhibit A. Elevated 2 psig delivery pressure CSST system configurations are shown in Exhibit B. The qualified installer is responsible for designing a system in accordance with building configuration, construction style, appliance loads, code restrictions, and available delivery pressure.

4. MATERIAL

4.1 General

Each length of pipe shall be examined prior to installation. Any dirt or obstructions shall be removed. Damaged, kinked, or otherwise defective pipe shall not be installed. Any burrs left by the cutting tool shall be removed.

When defective pipe or fittings are located in a gas piping system, the defective pipe or fittings shall be replaced. CSST splices or couplings may be used for repairs, but are not accepted for new installations.

4.2 Pipe

Steel pipe shall be at least standard weight (schedule 40) and shall comply with ASTM A53 or ASTM A106.

Corrugated stainless steel tubing (CSST) shall be tested and listed in compliance with the construction, installation, and performance requirements of *Interior Fuel Gas Piping Systems Using Corrugated Stainless Steel Tubing*, ANSI/AGA LC 1. Approved manufacturers are listed in Exhibit I.

4.3 Fittings

Threaded fittings for steel pipe shall be of steel, brass, bronze, or black malleable iron and shall be of standard weight, banded and beaded type. Bushings, all-thread (close) nipples, saddles, and cast iron connections are not permitted. Unions are permitted only as follows:

1. Between shutoff valve and appliance
2. Between system regulator outlet and manifold inlet
3. For insulating underground house piping

CSST fittings and components are part of the CSST piping system and shall be as specified by the manufacturer. Fittings are not interchangeable between different manufacturers of CSST.

4.4 System Regulators

Duke Energy's 2 psig delivery systems are equipped with overpressure protection devices designed to limit customer's pressure to 10 psig. Customer's regulators operating at 2 psig inlet must be capable of sustaining a 10 psig exposure without damage. System regulators listed in Exhibit I are approved for Duke Energy's 2 psig delivery systems.

4.5 Valves

All house-piping valves shall be approved for natural gas applications.

5. INSTALLATION

5.1 Meter Connection

Duke Energy gas meters and meter manifolds shall be partially supported by customer's house piping. CSST shall not be connected directly to the gas meter. Customer's installer shall use 1" or larger size steel piping to connect the gas meter to the CSST system. The steel piping shall be securely attached to the exterior building wall. See exhibit C for typical meter connections.

5.2 Support

Tubing shall be supported with metal pipe straps, bands, or hangers suitable for the size and weight of the tubing. Support spacing shall be as specified by the CSST manufacturer. Gas piping shall not be supported by other utilities. Structural integrity of the building shall not be compromised by the installation of gas piping.

5.3 Clearances

Where CSST is installed through floors, walls, ceilings, etc. the opening will be at least 1/2" greater than the tubing outside diameter.

5.4 **Bending Radius**

Changes in direction shall be accomplished with a generous bending radius to avoid over stressing tubing and fittings. Tight bends, kinks, twists, or stretching of CSST is not permitted. CSST manufacturers specify the minimum allowable bending radius.

5.5 **Tubing Beneath Floor Joists**

CSST may be routed beneath, through, or along ceiling or floor joists. Consideration shall be given to future construction such as finished basements. Striker plates shall be installed to protect concealed support points within 3" from edge of stud, joist, floor, or ceiling. See exhibit E for protection methods.

5.6 **Tubing Between Wall Joists**

CSST may be installed between wall studs if it hangs freely to prevent the possibility of being punctured by a 3" long nail. Striker plates shall be used at points of constraint through studs, joists, floors, ceilings or similar restraining type structures. See exhibit E for protection methods.

5.7 **Termination Outlet**

All piping outlets shall be installed to provide sufficient clearance from ceilings, walls and floors to permit use of a pipe wrench of suitable size without straining or bending the pipe. The outlet fitting or piping shall not be placed behind doors.

Termination outlets shall be securely closed and gas-tight with an approved threaded plug, threaded cap, or listed convenience outlet immediately after installation and shall remain closed until an appliance is connected.

A typical CSST termination outlet is shown in exhibit E. A flexible metal conduit or striker plate shall be used to protect tubing where movement is restricted and where tubing is at risk of puncture from a 3" long nail.

5.8 **Appliance Shutoff Valves**

Customer's installer shall install an approved shutoff valve ahead of the appliance controls, union, or approved flexible connector as the particular case may warrant. The valve shall be in an accessible location, and within six (6) feet of the appliance as measured along the piping run. Where local building departments invoke *CABO One and Two Family Dwelling Code*, the valve shall be installed within three (3) feet and in the same room as the appliance.

5.9 **Sediment Traps**

A sediment trap shall be installed where required to catch dirt or other foreign

materials. The sediment trap shall be at least ½” size and no smaller than the pipe to which it is attached. The sediment trap should be installed as close as practical to the inlet of the equipment, preferably downstream of the equipment shutoff valve. See typical furnace connection exhibit G for a sediment trap installation.

5.10 **Manifolds**

Manifolds are installed where multiple runs are made from a common location. Several configurations are possible, see exhibit D for typical manifold installations. Manifold installations must be accessible.

An approved shut off valve must be installed upstream of the system regulator for elevated 2 psig systems. Where Duke Energy performs house line inspections and pressure testing, a temporary nipple shall be installed in place of the system regulator. Customer’s installer replaces the temporary nipple with system regulator after pressure test approval and gas is turned on. Where local governments have assumed the responsibility for house piping inspections and testing, contact the local building department for installation requirements.

Customer’s installer may install approved shutoff valves on manifold outlet appliance runs. If appliance piping is 6 feet or less, a manifold outlet shutoff valve may be used as the required appliance shutoff valve. Permanently engraved metal tags shall identify an appliance for each manifold outlet shut off valve.

5.11 **Regulator Venting**

Regulators equipped with approved vent limiting devices and located in ventilated areas do not require breather vents to be piped to an outside location.

5.12 **Concealed Fittings**

When installing house piping that will be concealed, the number of concealed fittings shall be kept to a minimum. Concealed fittings are not permitted where CSST is installed in conduit.

5.13 **Tubing Under Concrete**

CSST shall not be directly embedded in concrete. CSST shall be routed inside a non-metallic watertight conduit with an inside diameter at least ½” larger than the tubing outside diameter. CSST concealed within conduit must be one piece with no splices or joints. See exhibit F for tubing installed within conduit.

5.14 **Outdoors**

When installed outdoors, CSST shall be protected from mechanical damage. A conduit or chase is required for installations in exposed unprotected areas within 6 feet of grade. Conduit shall be supported with proper size pipe hooks, pipe straps, bands, or hangers.

Protective coating must remain intact outdoors. Mechanical joints and associated exposed metal tubing shall be wrapped or protected by shrink sleeves. Appropriate measures must be taken to shield CSST from corrosive environments such as exposure to acid or chloride based cleaning solutions for brick or masonry.

Where passing through an outside wall, CSST shall be protected. CSST must be sleeved where passing through brick or masonry walls as shown in exhibit C.

5.15 Buried Outdoors

Buried CSST shall be routed inside a non-metallic watertight conduit with an inside diameter at least $\frac{1}{2}$ " larger than the tubing outside diameter. CSST concealed within conduit must be one piece with no splices or joints. Minimum depth is 18 inches of cover.

The non-metallic watertight conduit shall extend above grade and shall be properly supported to protect CSST from mechanical damage. If a building or structure is not available for support, a 4X4 treated post or equivalent shall be installed for support.

Conduit openings shall be sealed with a compound non-corrosive to stainless steel to prevent entry of water. See exhibit F for tubing installed within conduit.

5.16 Prohibited Locations

Except as otherwise provided in this section, gas piping shall not be installed in or pass through any air conditioning, heating or ventilating duct system, clothes chute, chimney, flue, or elevator shaft.

House piping may enter a duct system only when all the following conditions are met:

1. The gas utilization equipment is used to pre-heat outside make-up air.
2. The gas utilization equipment is approved for such use.
3. The use is confined to commercial/industrial occupancies.
4. The installation meets all local, state, or federal code.

6. HOUSE PIPING SHUTOFF VALVES

6.1 General

Duke Energy will install a shutoff valve on the inlet piping to every meter installation. In some situations the customer is also required to install a meter outlet valve at the meter set. Where the meter is not located at the building, a shutoff

valve shall be installed, by the customer's installer, in the house piping at the building wall and in an accessible location.

6.2 Multiple House Piping

In multiple tenant buildings supplied through a master meter or where meters are not readily accessible from the appliance location, an individual shutoff valve for each apartment or for each house piping system shall be provided at a convenient point of general accessibility. Each valve must be plainly marked with a permanent tag by the installing agency so the individual gas piping systems can be readily identified.

7. APPLIANCE

7.1 General

CSST gas systems terminate at the shutoff valve or termination outlet. Appliances shall be connected to the CSST gas system with rigid piping or A.G.A. approved flexible metal appliance connectors.

7.2 Gas Fireplaces/Log Lighter/Fire Place Piping

The appliance shutoff valve shall not be installed inside a firebox for log lighters, gas wands, or in any firebox that burns solid fuel. CSST may be used to deliver gas directly to the appliance shutoff valve.

NOTE: If the valve is in a finished basement or adjacent room, the valve shall be accessible through a door or open area and must be identified.

Shutoff valves supplied with gas log lighters are considered appliance valves and, therefore, require a separate approved shutoff valve.

7.3 Non-Movable Appliances

Central heating, unit heaters, room heaters, water heaters, incinerators and similar non-portable equipment may be connected directly to CSST provided sediment trap and appliance shutoff valve requirements are observed. See exhibit G.

7.4 Movable Appliances

A.G.A approved flexible metal appliance connectors may be used to connect domestic gas ranges, room heaters, refrigerators, fireplace heaters, clothes dryers, hot plates and similar portable equipment as shown in exhibit G. When a flexible connector is used, the connection shall be made to an outlet in the same room as the appliance and the connector shall not be in a concealed location.

7.5 Outdoor Equipment

Gas appliances mounted on concrete pads or blocks, such as heat pumps, air conditioners, pool heaters and Natural Gas Vehicle refueling systems, shall be connected to the CSST system at a termination fitting using either rigid pipe or an approved outdoor appliance connector.

Remote pad mounted gas appliances served by buried CSST may be connected directly to CSST. The buried portion of CSST must be sealed in watertight non-metallic conduit. Requirements for sediment trap and appliance shutoff valve must be observed.

Gas appliances attached to the building may be connected directly to CSST provided sediment trap and appliance shutoff valve requirements are observed.

Movable outdoor appliances such as barbecue grills shall be connected using an A.G.A. approved outdoor appliance connector. The connector shall be attached to the CSST system using a termination fitting or approved quick disconnect device. Permanently mounted gas grills may be connected directly to the CSST system.

See exhibit H for typical outdoor installations.

8. ELECTRICAL BONDING, GROUNDING AND CIRCUITS

8.1 Electrical Bonding

Each above ground portion of a gas piping system upstream from the equipment shutoff valve shall be electrically continuous and bonded to the grounding electrode system, as required by the *National Electrical Code*, ANSI/NFPA 70, 250-104 (b). Installation of bonding wire, clamps, and other bonding materials shall be as required by the local authority having jurisdiction for electrical installations.

8.2 Electrical Grounding

Gas piping shall not be used as a grounding conductor or electrode.

8.3 Electrical Circuits

Electrical circuits shall not utilize gas piping or components as conductors.

Exception: Low-voltage (50 volts or less) control circuits, ignition circuits, and electric flame detection device circuits shall be permitted to make use of piping or components for a part of an electrical circuit.

9. INSPECTION AND TESTING

9.1 General

This section is intended to provide the minimum testing requirements for CSST gas systems installed in the Duke Energy service area. All gas piping must be tested in accordance with these specifications. The gas meter must be disconnected prior to testing house lines. The requirements of this section apply where Duke Energy is performing inspection and testing of customer's house piping. Contact the local building department for requirements where the local jurisdiction is responsible for inspection and testing.

All testing shall conform to this section, the National Fuel Gas Code ANSI Z223.1 NFPA 54, local codes and local ordinances. It is the responsibility of customer's installer to insure that the gas house piping system is installed and tested in accordance with the prevailing local requirements at the time of installation.

Duke Energy shall not be responsible for any defective material or faulty workmanship or for any loss or damage arising from such defective material or faulty workmanship by the customer or their agent.

Many local governments have the responsibility for house piping inspections and testing. Please contact the local building department for installation requirements. In these instances, Duke Energy requires an approved house piping inspection & pressure test performed by the local inspection department before turning on a meter.

9.2 Inspection

All customer house piping must pass a visual inspection and pressure test by Duke Energy or the authority having jurisdiction before the meter is set and the line is placed in service. At the time the meter is installed, Duke Energy will perform a meter check to insure the customer house piping is tight.

As much as practical the entire system shall be made visible to the Duke Energy inspector. Transition from steel to CSST must be accessible for visual inspection. If any portion of the piping must be buried prior to completion of work, see 9.3 of this section. The customer must provide access to gas lines and equipment on roofs.

Approved house piping will be marked with a white tag, see exhibit J. House piping not approved will be marked with a red tag, see exhibit K. The tag will be placed on the house piping as near the meter connection as possible. A copy of the inspection form will be left in a weatherproof plastic bag affixed to the house piping meter connection. In most cases, this will be beyond the foundation wall on the outside of the building. See exhibit M for a copy of the inspection form.

9.3 Partial House Piping Inspection

Partial house piping inspections must be requested prior to covering buried portions of house piping systems including non-metallic conduit for buried CSST. This may or may not include the pressure test.

Approved partial house piping will be marked with a blue tag, see exhibit L. House piping not approved will be marked with a red tag. The tag will be placed on the house piping as near to the end of house as possible.

There is no charge for this inspection unless the piping fails the inspection and a second call must be made.

9.4 Pressure Test Requirements

Gas piping systems containing CSST will be tested at a minimum pressure of 10 psig for at least 15 minutes. This applies to both standard pressure delivery systems and elevated 2 psig delivery systems.

Where system regulators are required, regulator shall not be installed at time of pressure test. Customer's installer shall install a temporary nipple in place of the system regulator. After pressure test approval and gas is turned on, Customer's installer replaces temporary nipple with system regulator. Duke Energy will close and red tag manifold shutoff valve prior to turning gas on. See exhibit N for a copy of the red appliance shutoff tag.

EXHIBIT A

STANDARD PRESSURE SYSTEM CONFIGURATIONS

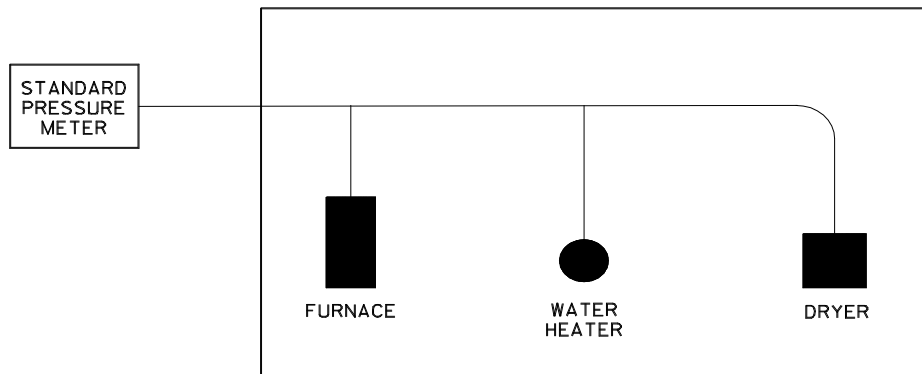
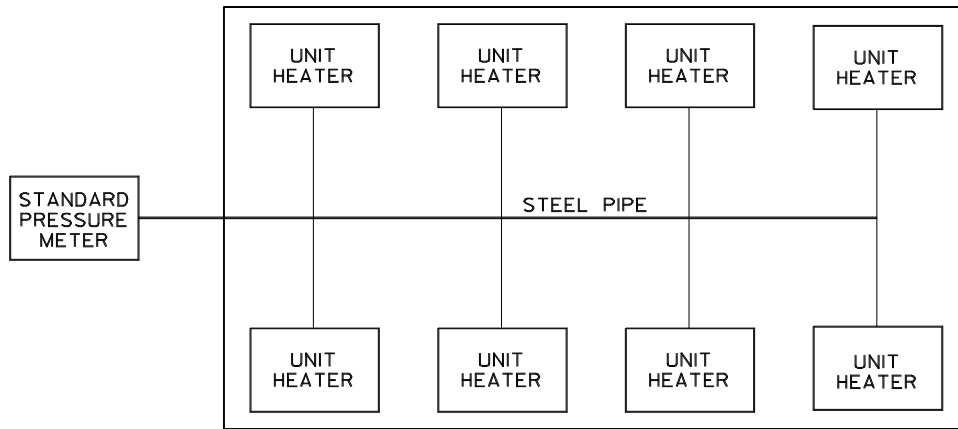
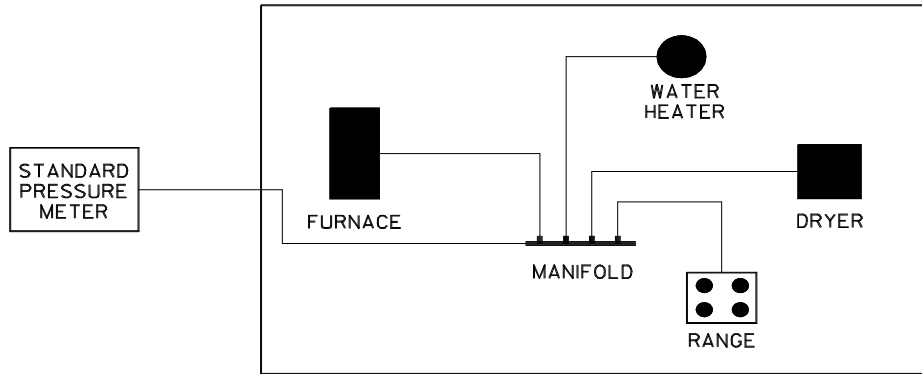

EXHIBIT B

ELEVATED 2 PSIG SYSTEM CONFIGURATIONS

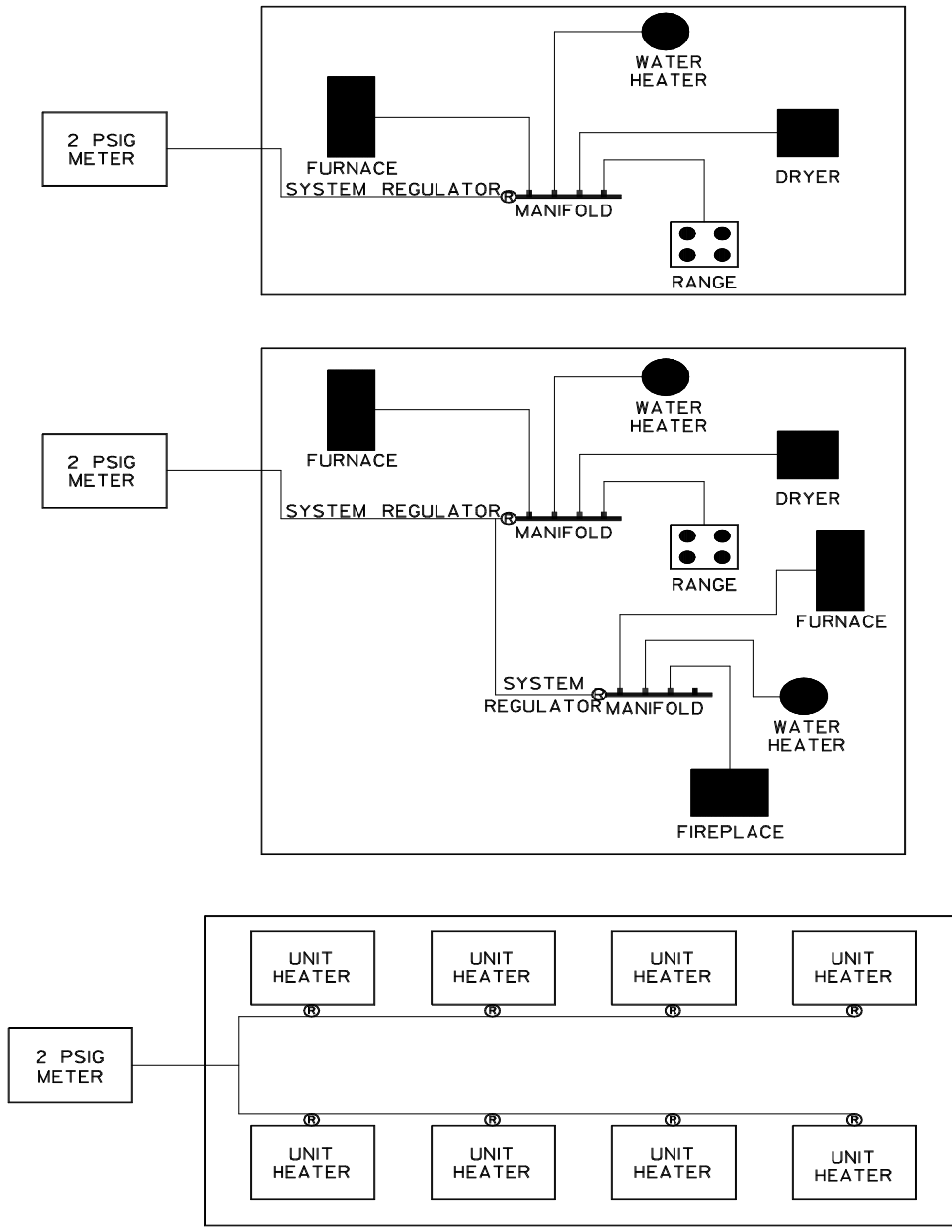

EXHIBIT C

GAS METER CONNECTION

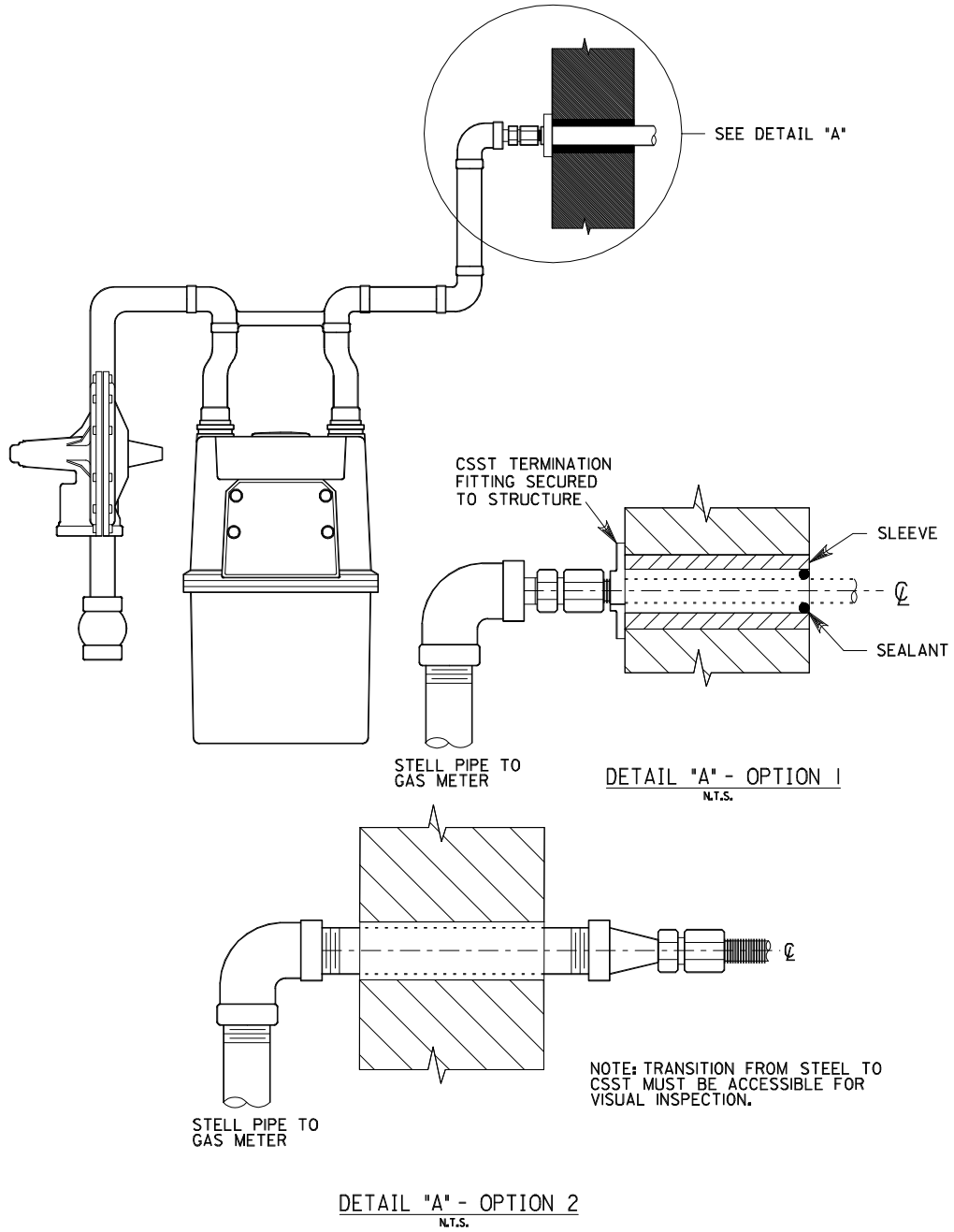
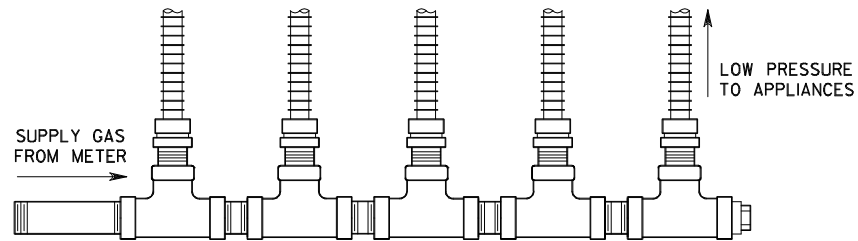

EXHIBIT D
MANIFOLDS



MANIFOLD FABRICATED FROM
PIPE NIPPLES AND TEES

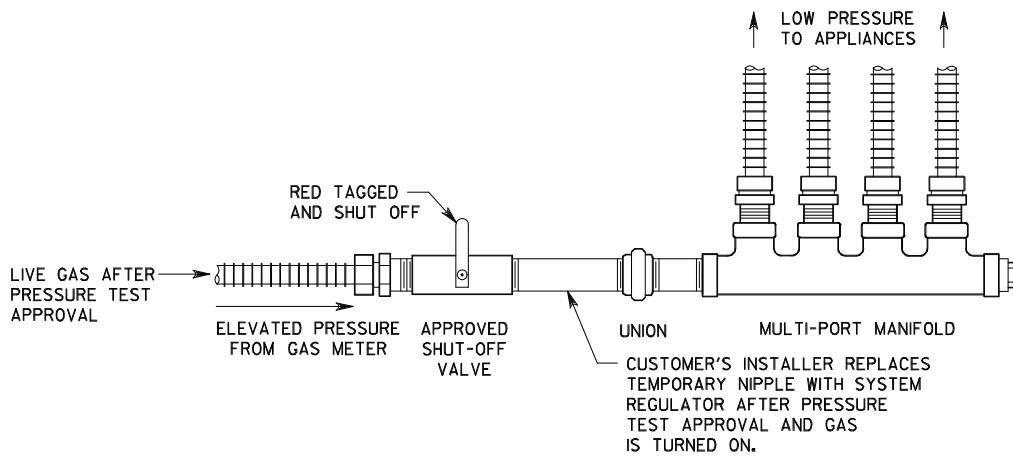
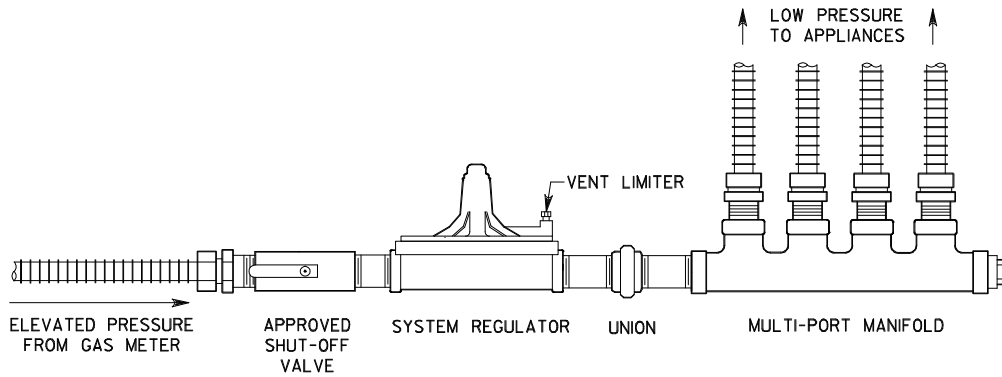

EXHIBIT E

CSST PROTECTION METHODS

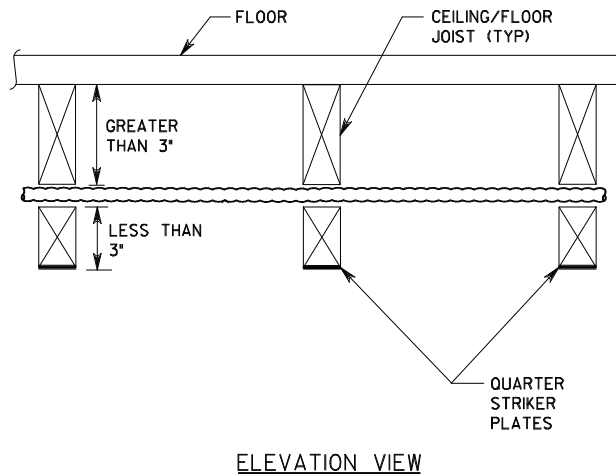
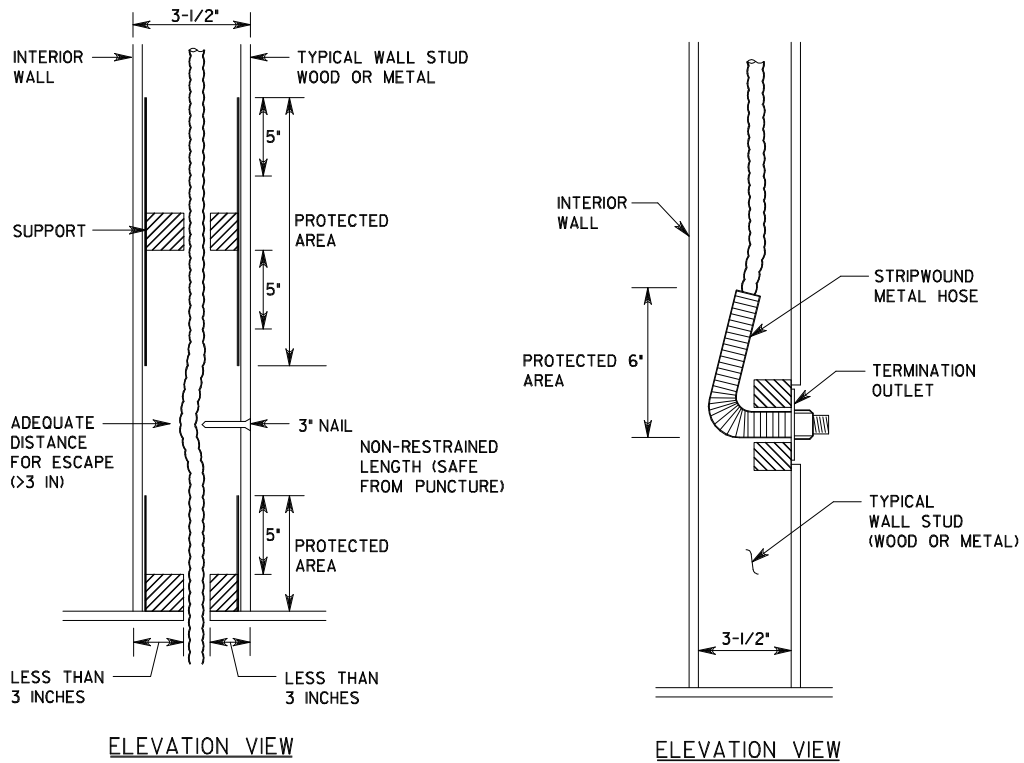

EXHIBIT F

BURIED/EMBEDDED CSST

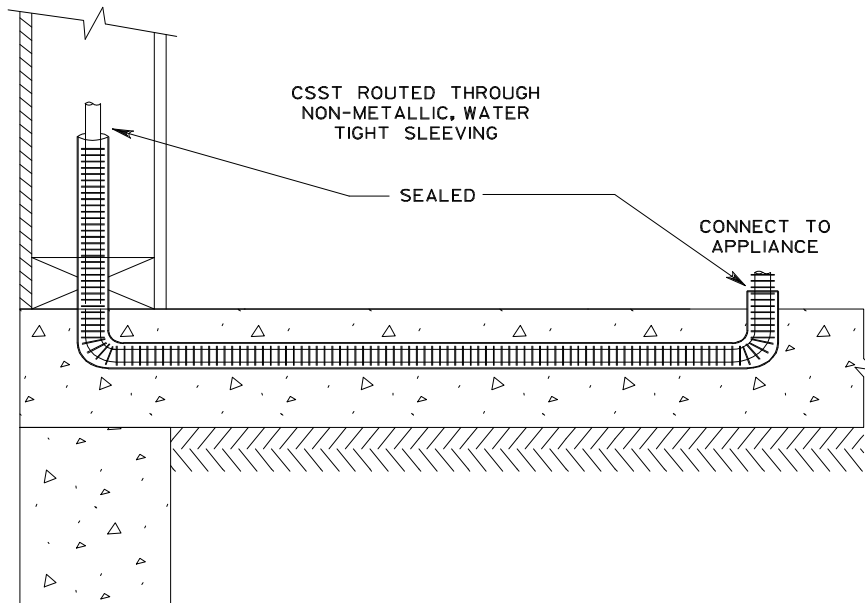
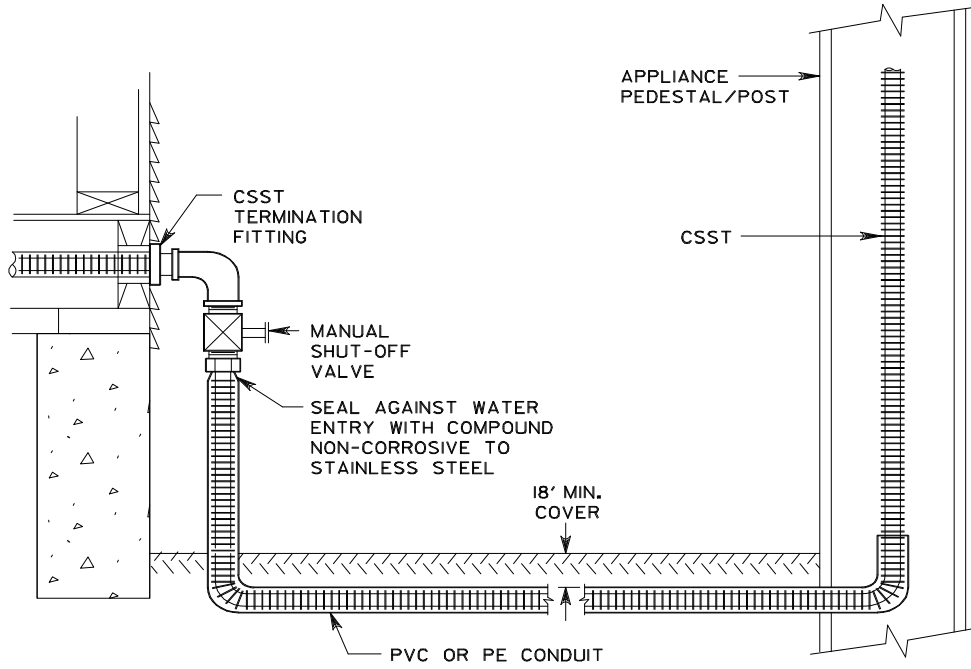

EXHIBIT G

TYPICAL INDOOR APPLIANCE CONNECTIONS

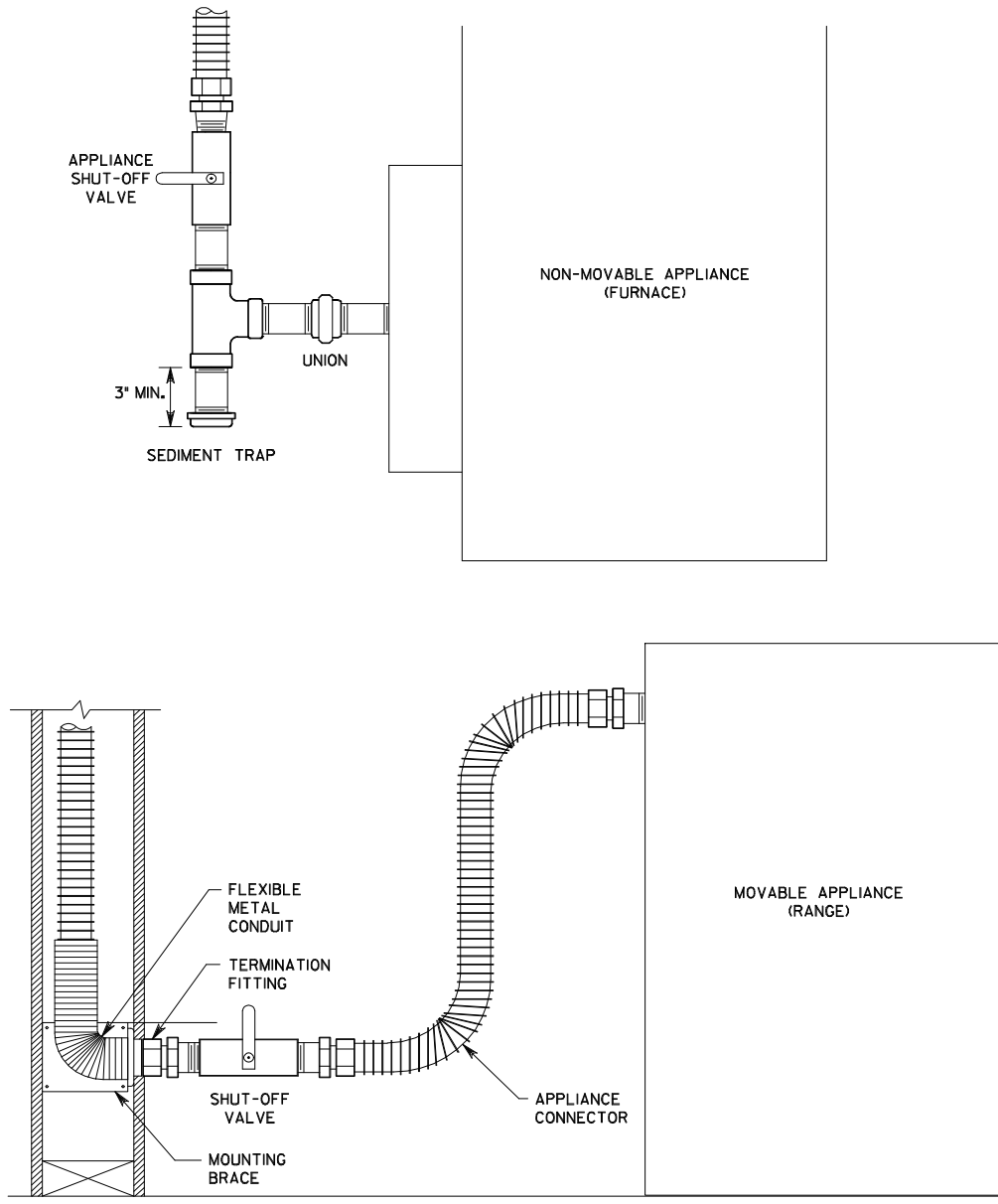

EXHIBIT H

TYPICAL OUTDOORS APPLIANCE CONNECTIONS

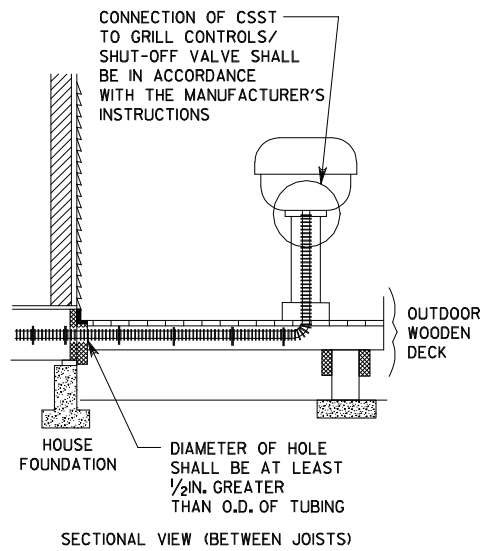
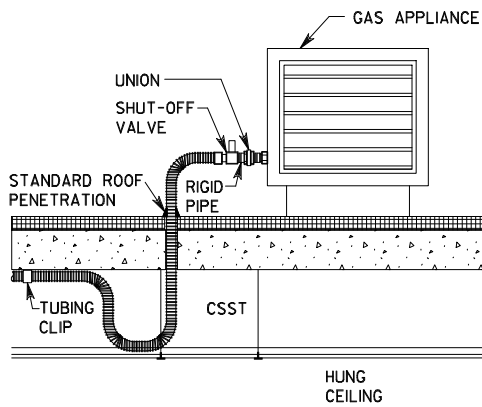
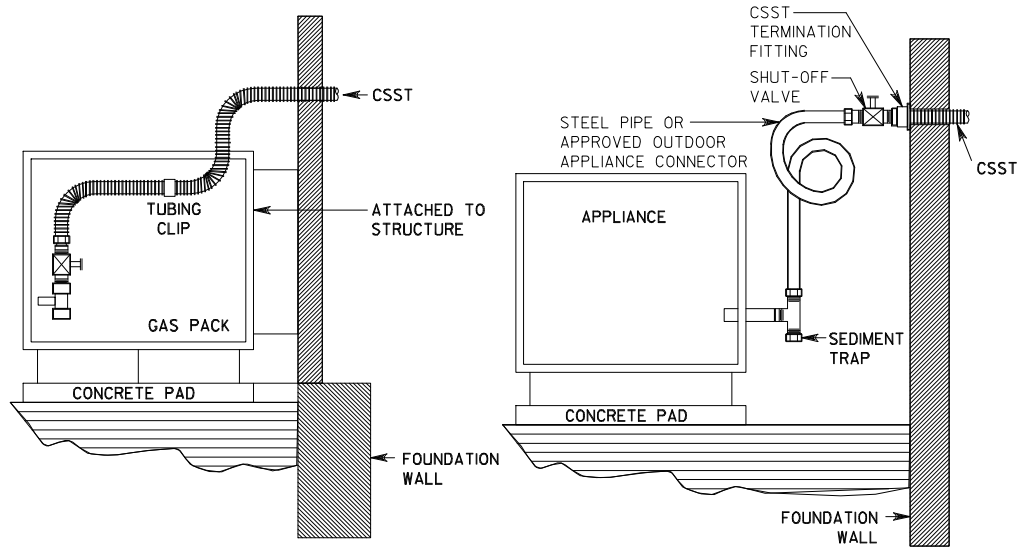

EXHIBIT I

DUKE ENERGY APPROVED CSST MANUFACTURERS

Gastite

Titeflex Corporation
P.O. Box 90054
603 Hendee Street
Springfield, MA 01104-0054

(413) 739-5631
(800) 662-0208

Wardflex

Ward Manufacturing
P.O. Box 9
115 Gulick St.
Blossburg, PA 16912

(717) 638-2131
(800) 248-1027

TracPipe

OmegaFlex
Subsidiary of Mestek, Inc.
251 Creamery Way
Exton, PA

(800) 671-8622

Parker PGP

Parker Hannifin Corporation
Parflex Division
Ravenna, Ohio 44266

(800) PARAFLEX (727-3539)

Pro-Flex

Tru-Flex Metal Hose Corp.
Highways 263 & 28
P.O. Box 247
West Lebanon, Indiana 47991

(800) 255-6291

DUKE ENERGY APPROVED SYSTEM REGULATORS

Maxitrol 325-3
Maxitrol 325-5A

OARA Type 300
OARA Type 600

EXHIBIT J

This form is used for final house line inspections.

ADDRESS		CITY			
APT./FLR.	TESTED AT	PSIG	FOR	MINUTES	
		FINAL INSP. <input type="checkbox"/>			
APPROVED <input type="checkbox"/>					
LA 128		SIGNATURE		DATE	

EXHIBIT K

(RED LABEL)

This form is used when house line inspections are not approved.

ADDRESS		CITY			
APT./FLR.	TESTED AT	PSIG	FOR	MINUTES	
PARTIAL INSP. <input type="checkbox"/>		FINAL INSP. <input type="checkbox"/>		VISUAL INSP. <input type="checkbox"/>	
NOT APPROVED <input type="checkbox"/>			CALL 421-9500		
REASON:					
A-116-R-2-GAS		SIGNATURE		DATE	

EXHIBIT L

(BLUE LABEL)

This form is used for partial inspection approvals.

ADDRESS		CITY			
APT./FLR.	TESTED AT	PSIG	FOR	MINUTES	
PARTIAL INSP. <input type="checkbox"/>		VISUAL INSP. <input type="checkbox"/>			
APPROVED <input type="checkbox"/>					
A-130-GAS		SIGNATURE		DATE	

EXHIBIT M

HOUSE PIPE INSPECTION CHECKLIST

A-893-R-1

DISAPPROVED _____

HOUSE PIPE INSPECTION CHECK-LIST

ADDRESS _____ NAME _____ DATE WANTED _____

SIZE _____ TEST AT _____ LBS. FOR _____ MIN.

COMPLETE _____ PARTIAL _____ NUMBER OF CHARGES _____

COMPANY: CG&E _____ ULH&P _____ LWBG _____

	YES / NO		YES / NO
Ready for inspection	___ ___	UNDER GROUND HOUSE LINE	___ ___
Holds pressure	___ ___	Proper depth min 18"/max 24"	___ ___
Totally exposed	___ ___	Properly cased	___ ___
Properly sized	___ ___	Properly coated	___ ___
Properly supported	___ ___	Anode connected properly	___ ___
Proper fittings & piping	___ ___	Insulated fittings	___ ___
Dirt Legs	___ ___	Properly controlled	___ ___
Metal tag on multiple	___ ___	House line tied in	___ ___
Valves, Union, Swing Joints Accessible	___ ___	Meter set	___ ___
Gas Is On	___ ___	Refer to Supervisor _____	

REMARKS: _____

SIGNATURE _____ DATE _____ TIME _____

EXHIBIT N

APPLIANCE SHUTOFF NOTICE

WARNING

GAS IS ON TO THIS VALVE.

APPLIANCE SHUTOFF

NOTICE

DO NOT RELIGHT OR USE THIS APPLIANCE UNTIL THE CONDITION(S) NOTED ON THE REVERSE SIDE OF THIS NOTICE ARE CORRECTED. CONTACT YOUR PLUMBER OR HEATING CONTRACTOR FOR NECESSARY REPAIRS OR REPLACEMENTS.

(OVER)

TA-181 R6 GAS

THE GAS TO THIS APPLIANCE HAS BEEN SHUT OFF BECAUSE IT IS UNSAFE AND MAY RESULT IN INJURY TO PERSON OR PROPERTY.

UNSAFE CONDITION: _____

ADDRESS: _____ DATE: _____ TIME _____

CINERGY®

COMPANY REPRESENTATIVE: _____