

NMRA/ NORTH SHORE & WESTERN DIVISION HO MODULE SPECIFICATIONS

Module Size:	Straight Module – 30” x 48” (not including railings or width of backdrop)
Height:	Floor to top of rail = 40” (Module height must be adjustable to +/- 1”)
Clearances:	Vertical from top of rail = 3” minimum Horizontal from center of track = 1” minimum This applies to, but is not limited to, all bridges, buildings, signals, and tunnels.
Mainlines:	Centerline of outer main track is measured 5” from front face of frame. Centerline of middle main track is measured 7” from front face of frame.
Branch line:	Centerline of inner branch line track is measured 9” from front face of frame.
Track designations:	Outer mainline is track #1 color code – Red (public viewing side) Middle mainline is track #2 color code – Yellow Inner branch line is track #3 color code – Blue (operator’s side)
Track ends:	Both the main lines and the branch line must end 4-1/2” from each end of the module.
Connecting track:	Each module is connected by a standard 9” piece of commercial straight track, Code 100, nickel silver, <i>Atlas Snap Track</i> .
Sidings:	Must be no less than 2” from mainlines or branch line.
Grade:	Mainline and branch line grade is 0%
Curves:	Mainline curves – 32” minimum Industrial curves – 24” minimum
Turnouts:	Main line must be at least Code 100, nickel silver, #6.
Diamonds:	Commercial Code 100, nickel silver diamonds are recommended.
Crossovers:	Must be insulated at crossover track to electrically isolate the two mainlines and the branch line.
Track:	Mainlines and branch line track must be Code 100, nickel silver rail and ties must be .045” thick (Atlas). Hand laid track is acceptable.
Roadbed:	Roadbed can be any material that is 3/16” thick.
Ballast:	Modeler’s choice.
Backdrop & Paint:	14” max. from top of rail. Color of sky - TBD

NMRA/ NORTH SHORE & WESTERN DIVISION HO MODULE SPECIFICATIONS (Continued)

- Highway Crossings: Roadway material must be at least 1/32" below top of rail.
- Uncouplers: None allowed in mainlines or branch line.
- Scenery: Modeler's choice.
- Signals: All block signal and grade crossing flasher systems shall be independently powered and will not employ track detector circuits which need to be connected to the track current to operate. Independently operated opto-electric systems are suggested alternatives.

General Electrical Specifications

- Connectors: All track power bus connectors shall be 2 pin "Jones" connectors.
Male: Cinch p/n - P302CCT or equivalent
Female: Cinch p/n - S302CCT or equivalent
- #1pin (wide) of connectors to be wired to the rail closest to the module front (public viewing side).
- Auxiliary connectors, not used for track power buses, may be any suitable connector of the modeler's choice.
- Wire: All interconnecting wire from module to module shall be 18 AWG stranded minimum. This includes track power bus and Accessory AC.
- Electrical isolation: All track off the mainlines must be electrically insulated from the mainlines, powered separately, and can be built free style.
Tracks #1, #2, and #3 **MUST NOT** have any common connection.
DO NOT use "COMMON RAIL" wiring. Gaps must be used on both rails on any crossover tracks.
- DCC network: All interconnecting DCC data line from module to module shall be 6 conductor flat phone line.
- Track Power: During normal module operation sessions Track #1 shall be powered and controlled with conventional DC power supply and throttle.
- During normal module operation sessions Track #2 shall be powered and controlled using DCC (Digital Command Control) by "System One" with the capability of switching to a conventional DC power supply and throttle if warranted.
- During normal module operation sessions Track #3 and all connecting yards and sidings shall be powered and controlled using DCC (Digital Command Control) by "System One".

NS&W Modular Specifications

Module size & track spacing standard

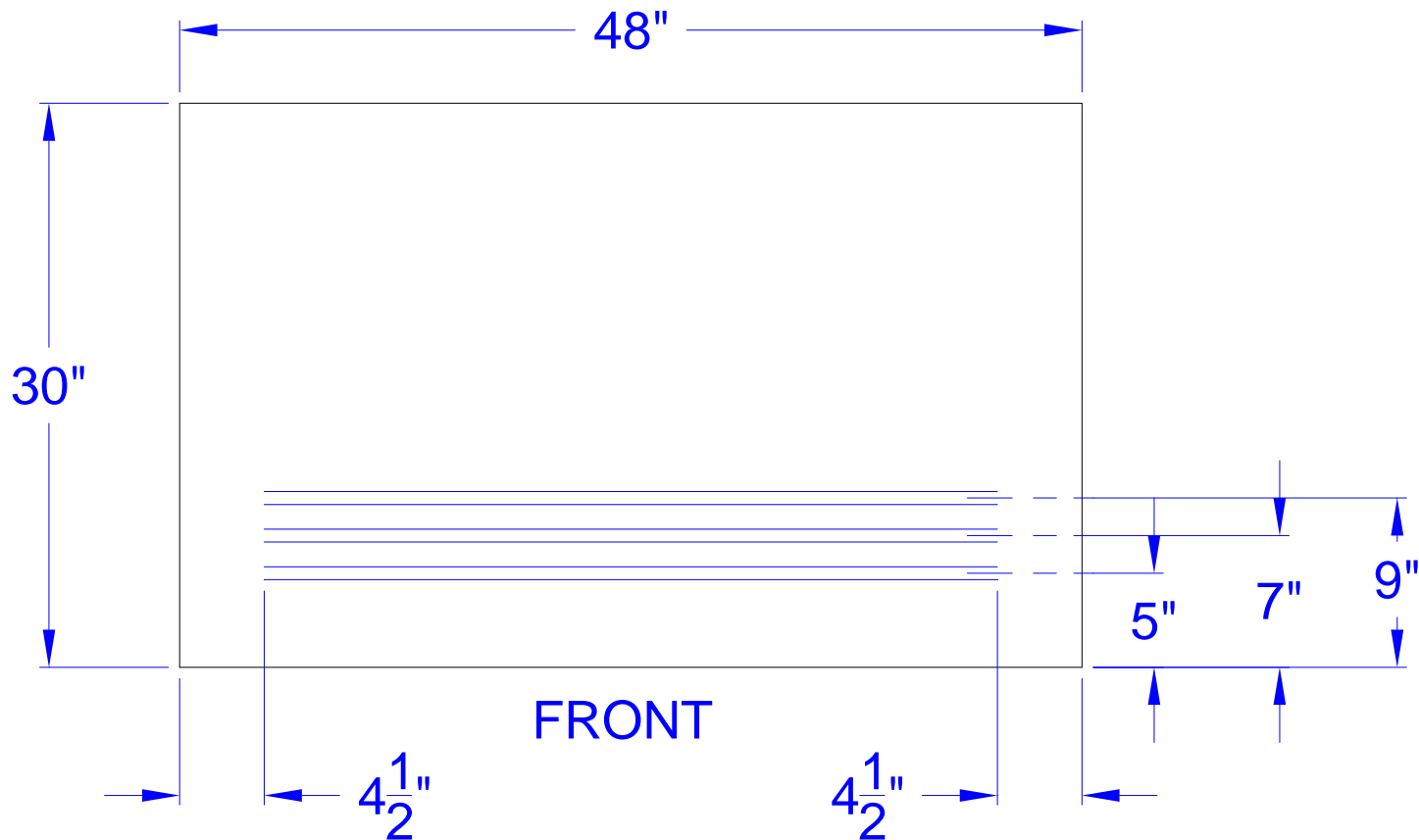

North Shore & Western Division, Midwest Region, NMRA

NS&W Modular Specifications

Module height standard

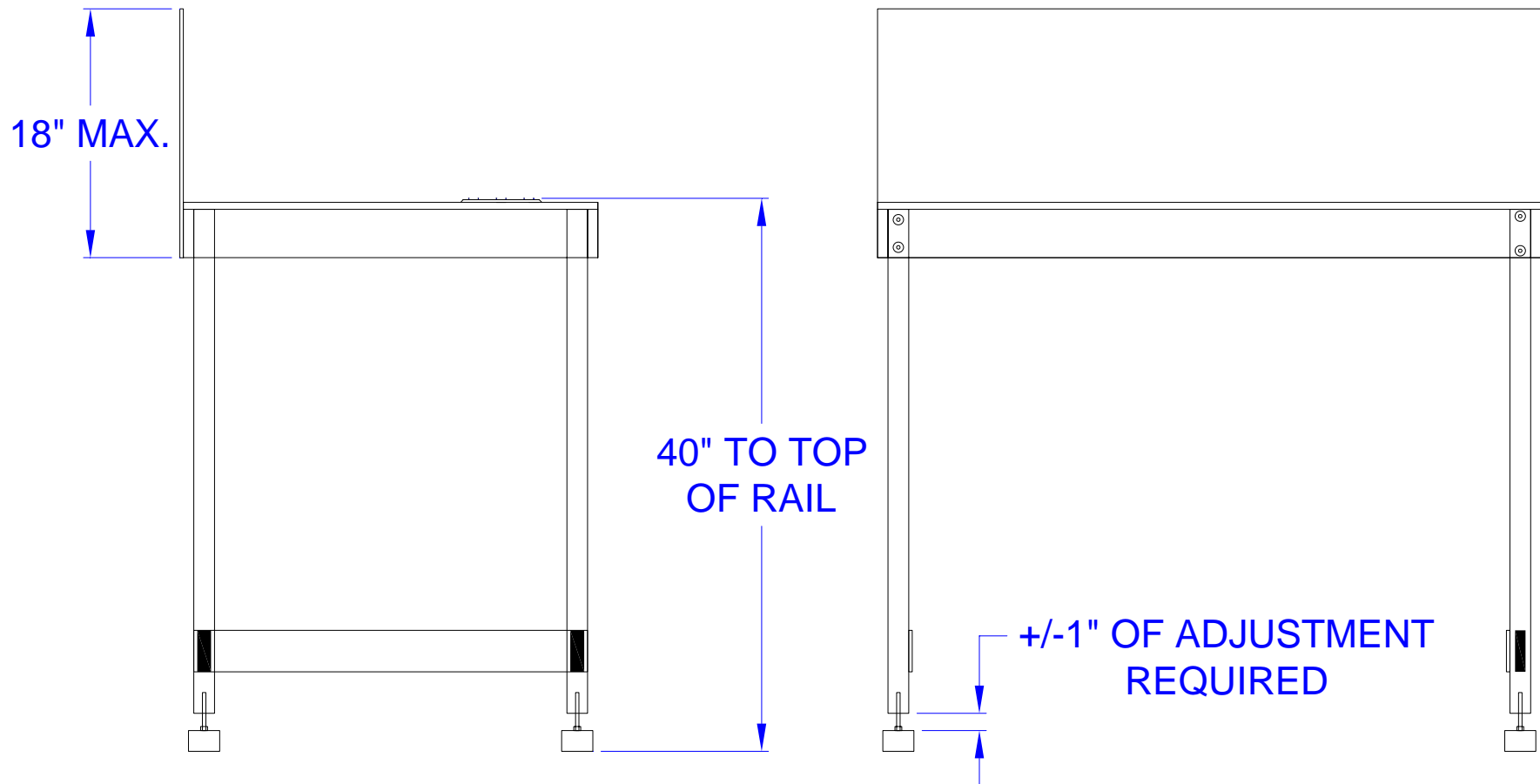

North Shore & Western Division, Midwest Region, NMRA

NS&W Modular Specifications

Module main bus line wiring requirements:
Use 18 AWG stranded wire minimum



FEMALE
CONNECTORS
AT THIS END
CINCH P/N S302CCT



MALE CONNECTORS
AT THIS END
CINCH P/N P302CCT

