

# Angelodyne

## MYSTERY TUBE REGENERATOR

### HIGH-OUTPUT LOW-VOLTAGE SINGLE-TRIODE SHORTWAVE RADIO

VERSION 1 ©2008

*The information below is not guaranteed to be free of errors.*

## 1. INTRODUCTION

The [Angelodyne](#) is a single-triode radio allowing normal volume listening at reduced plate voltages. On blowtorch shortwave stations I estimate sound power levels to be near [80 decibels](#). This eccentric SW receiver utilizes: a Hellenedyne triode tube; cathode-follower regeneration; [16-ohm](#) high-fidelity Koss Sparkplug phones ([112 dB SPL](#) per mW); and passive super-regeneration. The Angelodyne regenerator stemmed from the '*Hellenedyne radio research*', summarized below.

## 2. HELLENEDYNE TRIODES

Using a mathematical [power model](#), I concluded that we enthusiasts have been using the wrong tubes in our regenerators for about 50 years. Tubes exhibiting high [transconductance](#) and high [plate resistance](#) at low plate voltages are rare. Regenerators work best at low voltages: this is common knowledge. Unfortunately at these voltages most tube's geometry allow for nearly no power output. One active device ("[1AD](#)") regenerators were forever resigned to being mated with sound-powered phones. Audio sections were often left running lethal voltages to make up for the lack of detector gain. After looking over ~14,000 valves the model identified only seven low-cost triodes. I call these [Hellenedyne triodes](#) after the circuit they were designed for. Specifically they include single ([2GK5](#), [3GK5](#), [4GK5](#), [6GK5](#), [6FQ5A](#)) and dual ([4ES8](#), [6ES8](#)) triode tubes. The data for the model was obtained using hand calculations from manufacturers' [plate series curves](#). The triodes are all high-Gm, high-Rp, low-noise, low-capacitance, frame-grid VHF RF-amplifier valves.

Frame grid valves have: 1) high gain by positioning the grid closely to the cathode; 2) low noise since noise is inversely related to gain; 3) and low capacitances due to a shield between the grid and plate. They are [beam triodes](#): technology from 1958 that competed with transistors. The B7G-base [6GK5-series](#) valves exhibit a Gm of [7300 μMHOS](#) and Rp of [4660 ohms](#) at 20 V of plate. The B9A-base [6ES8-series](#) tubes have a blistering Gm of [9060 μMHOS](#) and Rp of [3110 ohms](#) at 20 V of plate. These tubes are capable of excellent power output at lower plate voltages if presented with a *weak* input signal. Many tubes, especially pentodes, are anemic at low voltages after being stripped of their plate resistance. Many older high-Mu tubes achieve gain by high-Rp but have low Gm. They cannot maintain the current required to output high power, especially at lower voltages.

TUBE name	Rp ohms	Gm μMHOS	Plate mA	Plate Volts	5:1 S3 mW	5:1 S0 CW mW
7721	1980	31720	18.9	40.0	57.252	5.153
6C45	3930	12500	6.8	40.0	13.169	1.185
6ES8	2625	16000	13.9	40.0	12.714	1.144
6CW4	5410	9760	6.5	40.0	11.471	1.032
E288CC	1660	13500	21.5	40.0	3.127	0.281
12K5	840	12500	60.0	30.0	0.648	0.058
49	5200	920	5.8	40.0	0.009	0.001
6GK5	5450	11000	8.5	40.0	16.650	1.499
6GK5	5330	9000	6.5	30.0	8.747	0.787
6GK5	4660	7300	5.2	20.0	3.625	0.326
6GK5	2770	6200	3.5	10.0	0.821	0.074

*Relative power output in mW (5:1 antenna coupled); S3 regen-mode or S0 CW-mode.*

## Hellenedyne

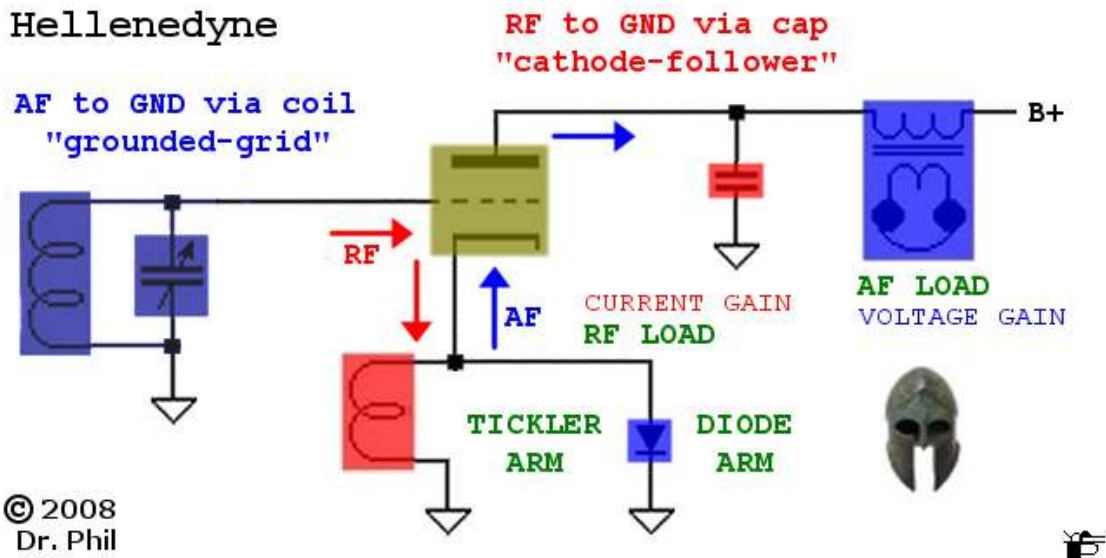

### 3. HELLENEDYNE CF/GG REFLEXING

The topology of the Hellenedyne was to be: [regenerative cathode-follower at RF](#) that is followed by [grounded-grid amplifier at AF](#). This radio was *cloaked in mystery*. [Corne](#) concluded that the diode was not doing detection. [Dave](#) found that the circuit resembled a plate detector. Above we see that a tiny capacitor to ground in the plate circuit sets up cathode-follower at RF. Tank RF enters the grid and exits the cathode. The RF load consists of a tickler and diode. The tank unit to ground sets up grounded-grid at AF. Diode AF enters the cathode then exits at the plate. [Sir Douglas Hall](#) created an analogous transistorized circuit in 1964 called the [Spontaflex](#).

### 4. CATHODE-FOLLOWER TICKLERS

Common knowledge states that High-Mu tubes make poor regenerators. This is true only due to plate loaded ticklers. Cathode followers protect [tank Q](#) with their high input impedances. Voltage gain is non-inverted and reduced to unity (one) for smooth regen. Output impedance is low: perfect for diodes and ticklers! Although there is no voltage gain, a [current gain](#) is present.

### 5. FEEDBACK-INDUCED GRID-BIAS CYCLING

Using the Hellenedyne I found that over-saturating the toroid caused super-regeneration. Heavy tickler current was likely rendering the plate circuit inoperable in a rhythmic pattern. This was not foreign to me as I read of a similar occurrence in [J. A. Worcester, Jr.'s 1934 Oscillodyne](#). The ramifications of this effect are huge. Radio Havana Cuba comes in at ~85 decibels SPL. It is likely that a minor variant will receive [BCB FM](#) and other [VHF AM and FM](#) communication. Single-triode BCB FM receiver plans have been drawn up. *Utilizing this effect with toroids could be new.*

It is essential to bear in mind the theory behind the Angelodyne. Audio four times greater than regeneration is possible and shortwave stations can be received with *no* antenna. Switching between regen and passive super-regen is seamless. Maybe the "sky is the limit" frequency-wise.

The theory is that tickler feedback is so great that it prevents electron flow off of the grid. **Faraday's** Law of electromagnetic induction states that a changing magnetic field will induce an electric current and corresponding electric potential difference. Hellenedyne-tube induced heavy tickler current sets in motion a chain of events: grid potential drops,  $R_p/G_m$  drop, plate current drops, [oscillations die out](#), negative charge leaks off the grid at a rate determined by a grid-leak resistor, and then the cycle repeats itself. *Is this part of the Hellenedyne mystery?* Larger signals disrupt the plate more often, causing less plate current, and audio is realized in the plate circuit. On MW this effect *may not* work as well due to the higher tank inductances. Critical factors may include: grid leak resistor value, toroid size, toroid turns, [spacing of the toroid windings](#), antenna coupling capacitor value, etc. Grid bias drops because cathode electrons randomly strike the grid.

