

Globe Patrol Junior

One-Transistor Medium Wave Radio

VERSION 1 ©2011



The information below is not guaranteed to be free of errors.

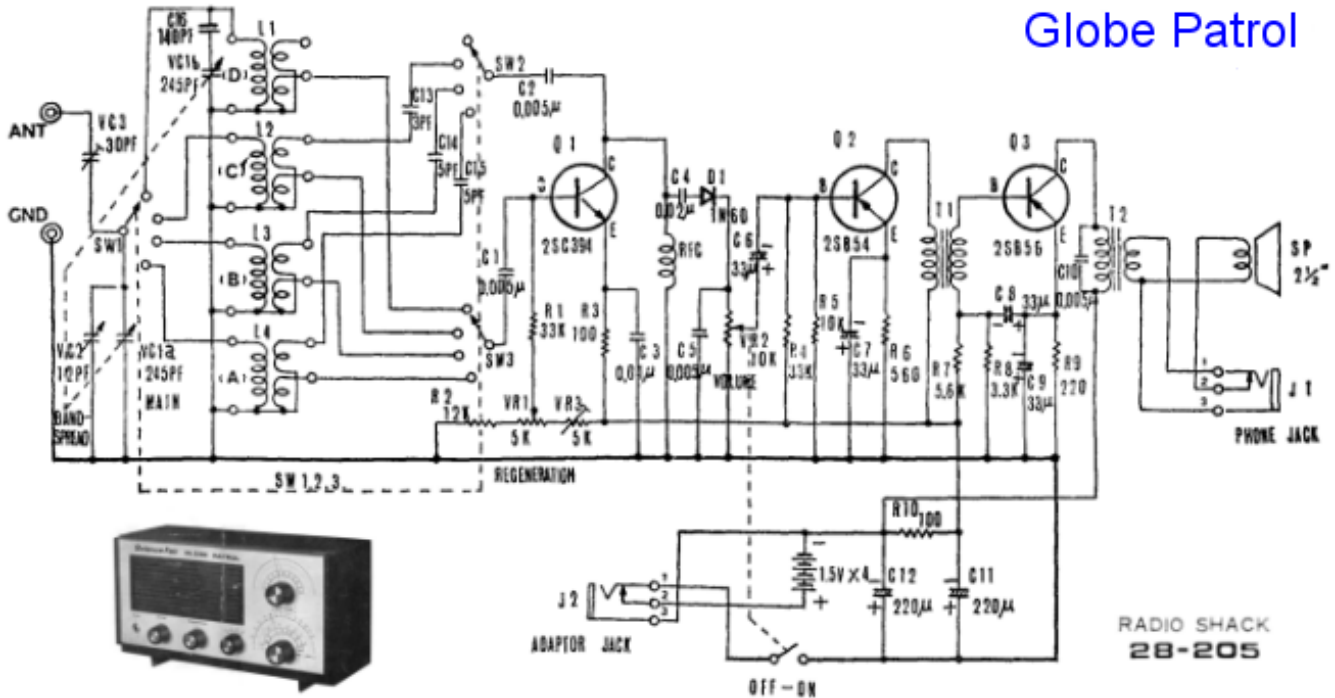

1. Globe Patrol

In 1972 the *Science Fair Globe Patrol* shortwave receiver appeared in *Boy's Life* magazine. This 51-component, 3-transistor, 4-band, regenerative radio was sold, as a kit, thru *Radio Shack*. It boasts a regenerative RF amplifier, diode detection, audio amplifier, and audio power amplifier. I reduced its design down to a 10-part, 1AD, low-cost, low-power, transformerless, diode detected radio for MW. The goal was to get beginners hooked on building radios. The design, although non-reflexed, looks similar to those by *Towler*, *Bazian*, *Wenzel*, *Macrohenrydyne*, *OldRadioBuilder*, etc.

2. Globe Patrol Junior

Use of a [crystal earphone](#) allowed avoiding costly 2000-Ω or sound-powered phones, large audio transformers, and deafening piezos. The collector's unbypassed [RFC-diode-phone](#) circuit was researched and looks akin to a crystal set's *selectivity enhancement circuit*. The crystal ear's 15nF of capacitance takes both RF and audio to ground. There is no saturation "pop" like a reflexed set.

The *Globe Patrol's* 2SC394 transistor was replaced with an [MPSA18](#); its high DC gain (hFE) increases input impedance. Common-emitter results in maximum power gain and its voltage gain is related to load. A BJT is more [durable](#) and has a [higher transconductance](#) than a JFET. Regen is controlled by altering base current: 3.2 μA maximum. At 600 hFE and 1.5V, current is kept below 1.9 mA. The radio, built on a 10k-Ω pot, is ideal for miniaturization: inductive tuning can be used.

The *Globe Patrol's* four-bands (tanks and rotary switch) were pruned to a single band. The 4 "C" batteries were replaced with one 1.5 V "D" battery: a Duracell alkaline will last ~7000 hours.

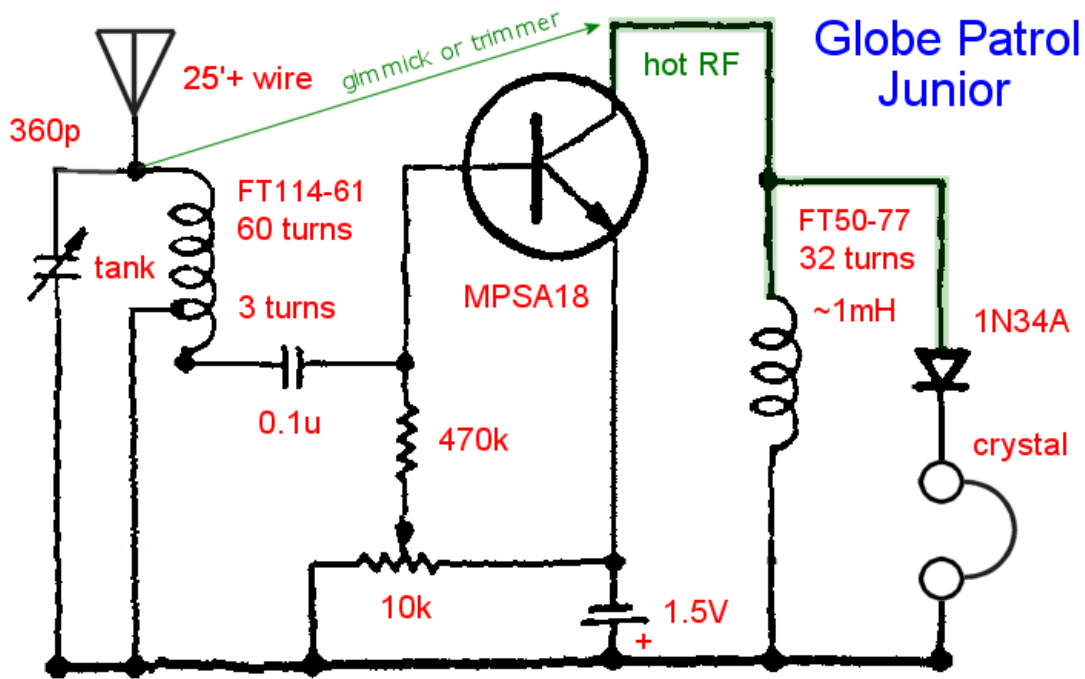

The **Globe Patrol Junior** uses 3-turns below ground for input into the NPN transistor's base. This provides current gain (BJT's are current controlled) and collector RF is in-phase with the tank and antenna. Collector energy provides regeneration. The 470k-Ω resistor limits MPSA18 current. Do not use over 6 volts without adding a 100-Ω emitter resistor and 0.01 μF bypass cap. With an ammeter hooked at the battery positive, rotate the pot, and mark 0.5 mA increments on the dial.

Keep all collector wiring as short as possible. The positioning of the choke is critical. Use a 1 to 10 mH choke. Crank in 1.5 mA of current, position and orient the choke, relative to the tank's inductor, until strong regeneration occurs. For more regen (a toroidal choke and tank shields RF), solder a wire at the top of the tank and lay it near the collector (or any hot RF green line above).

The **Globe Patrol Junior** makes a good base for experimentation. Try an antenna trim cap, antenna input taps, 720 pF tuning cap and a 43 turn coil, other diodes, a 1000 pF phone bypass, alter the 0.1 μF capacitor, use a junk radio's ferrite rod, wrap 16-turns on this rod for shortwave to ~6 MHz (or use 20-turns on a T130-2 toroid and add a trim cap from the tank to the collector), tune by moving the rod in and out of the winding, use a 100k-Ω pot (using "0" as an "off"), vary the turns into the base, etc. Or add the design to a crystal set using a few-turn base pickup coil, maximum regeneration, and physically move the coil closer to the tank. The radio is loud enough to enjoy your top local MW stations or big-gun shortwave stations. Be sure to also listen at night when transmit power is boosted. Varying base current can often be used to pull in a new station.

3. Discussion

The **Globe Patrol Junior** captures the excitement of the **Globe Patrol** kit without the expense or work. I'd love to see **Dave Schmarder** build this as a second solid-state radio. It would make a good starter *one-active-device* radio for a *parent-child* team or an inexpensive science fair project.



just_rtfm@<NOSPAM>yahoo.com
http://home.comcast.net/~phils_radio_designs

Copyright 2011
 Dr. Phil