

Heliosdyne

Single Transistor FM DX Receiver

VERSION 1 ©2011



The information below is not guaranteed to be free of errors.

1. INTRODUCTION

There are two popular single-transistor FM radio designs on the net. The first, called [Andy Mitz's One Transistor FM Radio](#), appears on his [FM-Only Radios](#) site. Andrew's design: is made of 24-parts, exploits common-gate JFET super-regeneration, tunes using two variable capacitors, and uses a [TL431CLP](#) as an audio amplifier. The TL431CLP is a programmable shunt regulator. It is an active device consisting of an on-chip voltage reference, operational amplifier, and NPN transistor.

The second FM design, called [The Radio Shack Special](#), was designed by [Sir Pedro](#). Pedro's design: is made of 21-parts, exploits common-gate JFET super-regeneration, tunes via one variable capacitor, uses a home built radio choke and gimmick capacitor, has two potentiometers, and uses an [LM386](#) as an audio amplifier. The LM386 is a low voltage audio amplifier that contains about 10 transistors. For more information visit [Patrick Cambre's](#) site: [Set Sail with Sir Pedro and Patrick...](#)

2. HELIOSDYNE

The Heliosdyne is a solid state version of my [Angelodyne](#) detector. The Angelodyne can be a [super-regenerative drain detector](#) capable of FM demodulation. The Heliosdyne was designed as a single transistor FM radio that uses no extra active devices for audio amplification. It was made for hearing distant or weak signals, so-called FM DX. The radio uses 21-parts and consumes 2 mA, or 18 mW. The Heliosdyne, differing from Andy's and Pedro's radios, has no printed circuit board, no mechanical tuning capacitor, and no custom gimmick capacitor (as with *The Radio Shack Special*).

At radio frequencies the Heliosdyne uses [common-drain](#) (aka source follower) which makes for very high input impedance, about 100M ohms. The output is of low impedance and high current. This is ideal for adding energy back into the tank. The tank itself consists of a home built inductor: seven turns at a diameter of 10 mm and a length of 37 mm. The coil can be bent to fit the range. For the other seven turn inductor use a pencil as a form and compressed it as tightly as possible.

The tank uses two varactor tuning diodes (MV2105: rated 6.8 pF to 30 pF, Q = 400) being fed via a 10-turn potentiometer. [Tuning is so precise that the stereo and high energy mono channel can be resolved separately](#) (if the amplitudes are sufficient). The 1M ohm resistor insures that no RF energy will be flowing in the tuning control. There is no hand capacitance or skipped stations.

At audio frequencies the Heliosdyne uses [common-source](#) for maximal power gain. Stations are [not loud but easily heard](#). Many stations can be listened to hour-after-hour. An RF choke keeps the Bogen T725 audio transformer and regen control clean of radio energy. The two 16-ohm Koss Sparkplug earbuds are paralleled (8-ohms) and brought to 40k ohms via the T725. [A hobbyist with sound-powered phones will have ~18 dB on my setup](#). The antenna, 25' of wall-mounted wire wrap, is grounded and moved from 5 cm to 1 cm away from the tank's end. Re-tuning can be necessary.

Unlike MW or SW, FM is unforgiving of sloppy design. The receiver should be rigid and built exactly as shown. The placement of all but the controls, transformer, and headphones are critical. **Keep everything, including ground, away from the tank.** The J310 (J309 is preferred) JFET is static sensitive. So avoid touching the gate (or ground), solder the gate last, and check the circuit before adding power. With a source follower, if the *source line* comes unhooked a hole will be punched in the JFET's gate. The center (source) lead can be handled. **Distortion may indicate a damaged gate.**

To use the Heliosdyne: turn the pot to the end with the high pitched squeal. Reduce power until the squeal disappears. Or use the point before the sound stops. Or another, below the silence. Tune to a weak station or background noise to fine adjust. Avoid loading the tank with the antenna.

The Heliosdyne can be miniaturized by using a small transformer and trimmer pots. The 0.22 μF capacitor and inductor in parallel with the source load form an *audio voltage gain enhancer*. The enhancer can be removed if the 0.001 μF source capacitor is increased to 0.22 μF . Performance is optimal as shown. The varactor system can be replaced with a trimmer cap. **Use fresh batteries** or regen will be harsh. Piezos can be used instead of earphones. Also see the **Angelodyne Detector PDF**.

3. SCHEMATIC

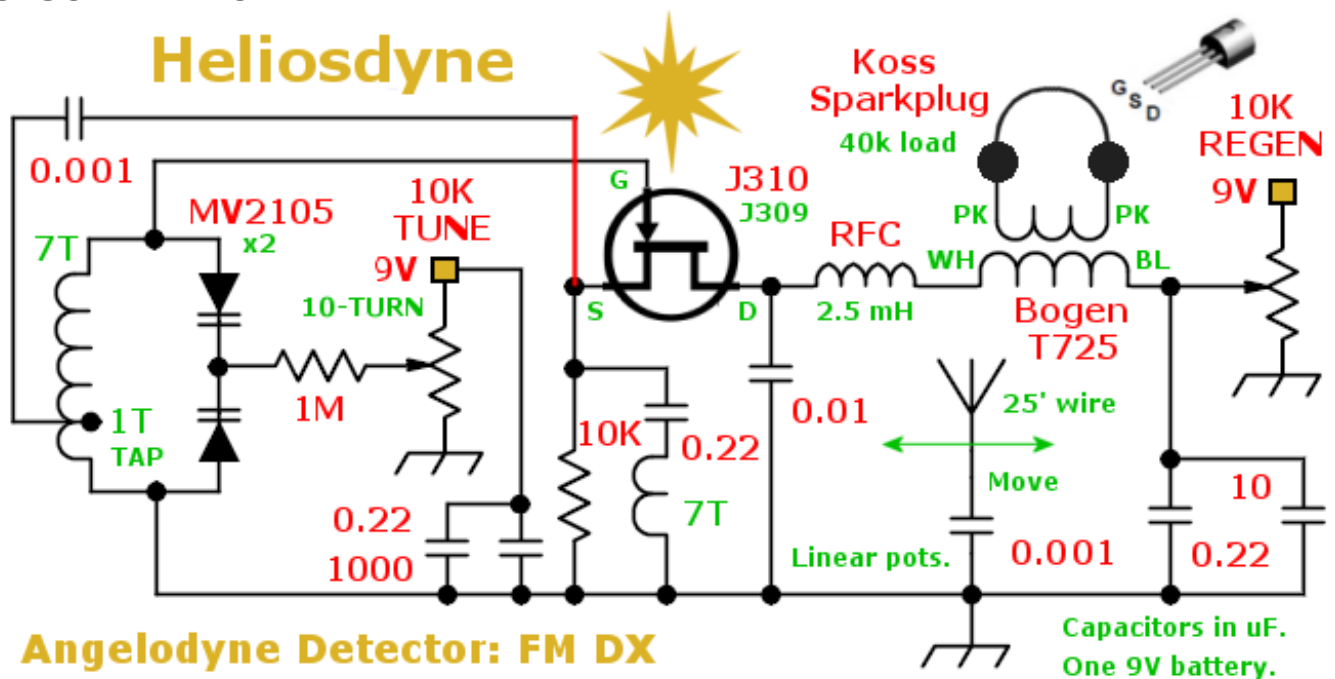

4. DISCUSSION

The **Heliosdyne** is a super-regenerative design that has enable me to pursue the hobby of **1AD FM DX**. This is a **prototype** and subject to fine tuning. I released the Heliosdyne early due to its performance. In my first sitting, after the radio was running, I logged **42 FM stations**. And this was without searching dusk or dawn, or varying antenna coupling, or using a directional dipole. I'd like to thank Andrew, Pedro, and Patrick for their fine work. My hope is that the Heliosdyne design will inspire hobbyists to undertake a new hobby: **1AD FM DXing**. God bless you and happy DXing.

SEE PHOTOS OF THE HELIOSDYNE IN A COMPANION PDF



just_rtfm@<NOSPAM>yahoo.com
http://home.comcast.net/~phils_radio_designs