

Hellenized SRF-59 Handbook

QRP Image-Rejecting Low-IF Shortwave Receiver

VERSION 1 ©2011



The information below is not guaranteed to be free of errors.

1. SONY'S UNIQUE SRF-59

This document describes converting the [Sony SRF-59](#) to shortwave. Its companion article is named [Hellenized SRF-59](#). The Sony contains a robust proprietary [bipolar junction transistor](#) chip: the [CXA1129N](#). Selectivity is achieved via active [55-kHz RC intermediate frequency filters](#); image rejection consists of adding the output of [phase shift networks](#) that follow two [I/Q mixers](#). The SRF-59 is a high-tech alternative to using dual conversion and ceramic IF filters. This analog design is both low-noise and low-power. The SRF-59 can run [180 hours](#) on a single "AA" battery.

Most quality shortwave receivers are digital to assist tuning. However, their topology also contains a noise-producing microprocessor, liquid crystal display, and synthesizer. Band scanning for strong stations is much easier on an analog set. Double conversion means more inline mixers and more noise and power. The SRF-59's 55-kHz filters sound better than many 450 and 455-kHz filters. The Hellenized SRF-59 has as good a sound (warm, clean, rich) as any radio I have heard, including the Drake-designed [Satellit 800](#) and [Eton E1](#). Its sensitivity and selectivity permits both long-distance DXing and enjoyable program listening. The SRF-59 costs ~\$20, shipped, on eBay.

2. MATERIALS

The Hellenized SRF-59 modification requires five parts: two [T50-2](#) toroids, a [100 Ω](#) resistor, a [0.22 μF](#) capacitor, and a variable capacitor. Ideally a chassis will house an air-variable capacitor (ex. 360 pF) with a large tuning knob, vernier drive, and dial indicator. The iron powder toroids can be bought from [Amidon](#). The stout Sony [SRF-39](#) and [SRF-49](#) (available used) can also be modified.

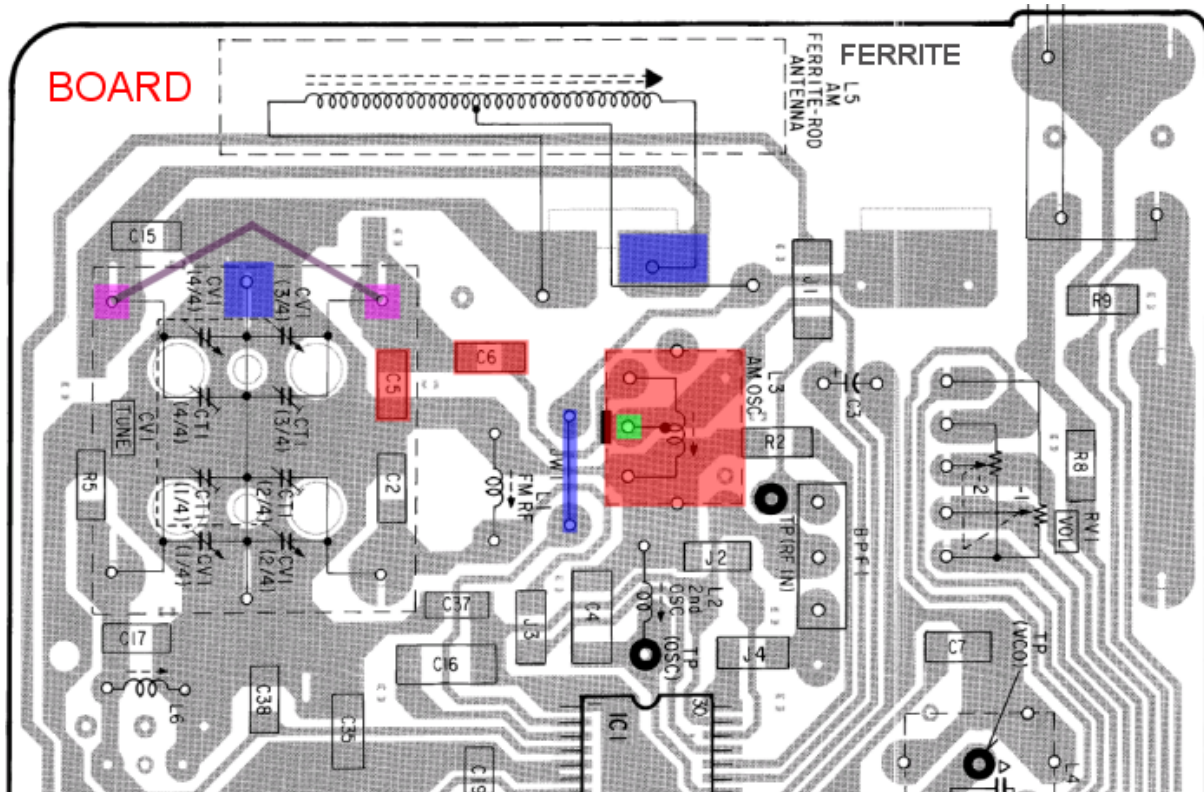

3. SHORTWAVE FREQUENCIES

The hottest shortwave bands during the nighttime are 49M, 41M, and 31M; or 5.7 to 10.0 MHz. Daytime hot spots include 25M, 22M, 19M, and 16M; or 11.5 to 17.9 MHz. This modification will center on receiving ~5.7 MHz to 17.9 MHz to include the majority of shortwave programming.

WARNING: Please do modifications while wearing **EYE PROTECTION**.
CAUTION: Modifying radios can easily result in their damage.

4. OPENING THE SRF-59

To open the SRF-59 simply remove the two screws from the back, lift the circuit board at the battery end, and gently pull it rearward so that the headphone jack clears its retaining circle.

5. ANTENNA MODIFICATION

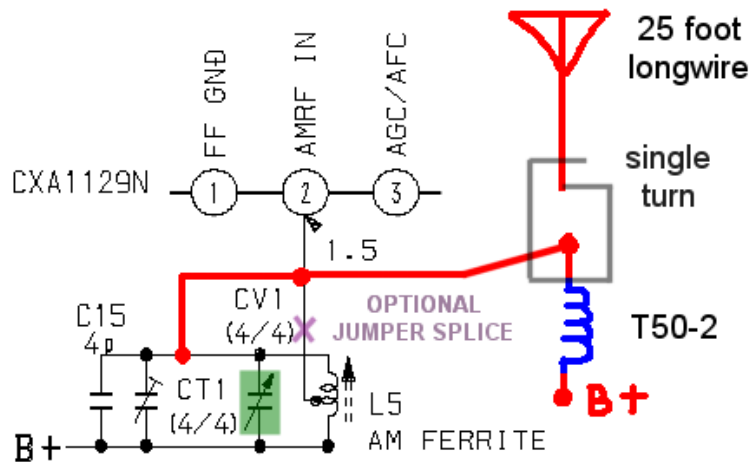

The AM ferrite rod antenna system must be altered for shortwave reception. Sony uses a tuned input. Their engineers typically apply antenna tank input to a transistor's **emitter**, making them a **low-Z** input. This invites tapping down on the tank for current. SRF-59 sensitivity is ample without an amplifier: ~1.6 μV or **S4**. The T50-2 toroid could be omitted (at shortwave the ferrite appears as resistance); but it is critical to high performance to reduce mixer energy. We prevent overload by using a tuned input consisting of **25 turns** on a T50-2 toroid, or **3.1 μH** . The SRF-59 tuning wheel is used as an antenna tuner. I left the ferrite rod intact: MW energy is dumped and inductance does not add in parallel. You can experiment using a (tuned) loop instead of the toroid.

Although B+ (1.5 V) is applied to the chip, it is key to note that B+ at radio frequencies is at ground due to three decoupling capacitors. The incoming antenna wire is looped a single turn around the antenna's tuning toroid and then back on itself to form a **gimmick capacitor** (this can reduce FM noise). The design prevents DC from entering AMRF_IN and prevents overload (which easily occurs with antennas hooked more directly to the toroid). **With overload there will be hiss instead of any radio stations.** I found the **Q** or quality factor of the antenna tuner to be excellent. Tuning is sharp and this prevents stray RF from entering the chip. One caveat: with the antenna detuned even strong stations will sound poor. See below for details on properly tuning the radio.

Look closely at the **BOARD** layout on the previous page. The blue parts are needed for the antenna system changes. Study the side of the board with the two chips and notice how the lines correspond. The left blue block is a tap to a big solder blob on the tuning capacitor. This provides B+ power beyond the power switch. It is the bottom of the tank. The right blue block is a tap to another solder blob and is the top of the tank. The lower blue line is the tap going into the chip's **AMRF_IN** (pin 2). The line is a jumper on the component side: it can be cut to bypass the ferrite. Avoid damaging the jumper because the chip's pins are spaced too close to solder on. **The purple blocks were connected via a wire.** This mod will add the oscillator's variable capacitor (CV1 $\frac{3}{4}$) to the antenna tuner. A photograph below shows how to protect the chip's 4 taps using a solder lug.

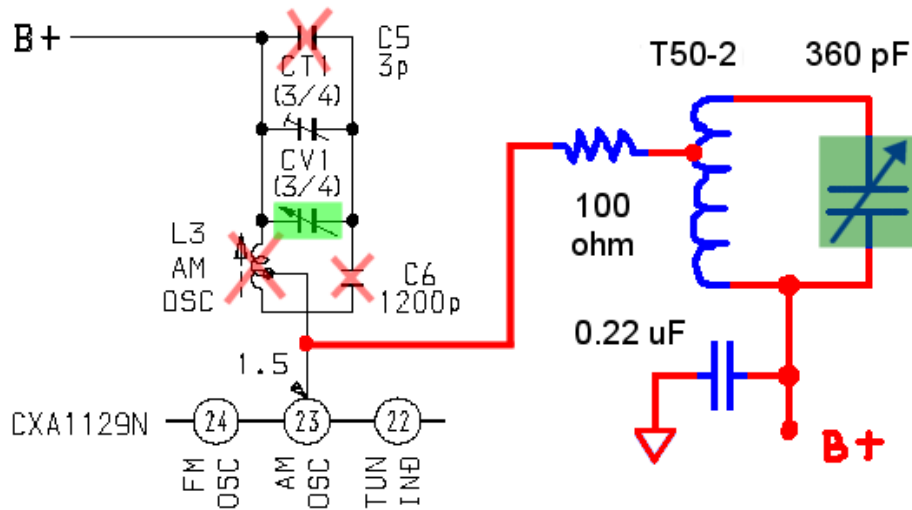

6. OSCILLATOR MODIFICATION

The local oscillator (LO) must be altered for shortwave reception. It is essential to realize that **the LO is twice the receive frequency** due to the CXA1129N's internal $\frac{1}{2}$ divider. The higher tuning range, above 15 MHz, would ideally use a different toroid. A T50-2 toroid is resonant from **1 MHz to 30 MHz**, meaning it can tune the SRF-59 up to ~ 15 MHz. Sony engineers typically apply oscillator tank input to a transistor's **base**, making this a **high-Z** input. Unlike a FET, bipolar bases respond to current, not voltage. It was necessary to use a 100 ohm resistor in the circuit. At SW frequencies, $100\ \Omega$ has the impedance of a 150 pF cap; but allows DC to enter **AM_OSC** (pin 23). Without resistance, tuning was not effective. I used **12 turns** on a T50-2, or **706 nH**. The tap was placed **5 turns** from the top of the tank. You can experiment with turns, tap, and omission of the resistor. I used a **0.22 uF** capacitor (value is non-critical) to bypass any stray RF at B+ to ground.

I used my reliable **Heathkit Signal Generator** with its tuning dial, vernier, and air-variable capacitor of **360 pF**. Using a smaller capacitor or putting one in series will make tuning the radio easier but cover less range. Different coils can be used or a larger type "2" toroid, bus wire, and alligator clips. Another viable tuning option is using varactor diodes and a **10-turn** potentiometer.

WARNING: this section will alter your radio and could result in it being destroyed. The AM oscillator must be removed. It is on the component side of the board: a silver metal box with red circle. See the **BOARD** layout. This canister must be de-soldered. It is crucial not to apply heat for extended periods: the board is fragile and lines can easily become lifted. The internal capacitor is rendered inoperable by removing two capacitors: **C5** and **C6**. See the small red rectangles on the **BOARD** layout. You can de-solder them or grasp them with pliers and torque them off. The green square on the **BOARD** layout indicates the location of the pad where the oscillator tap is soldered.

7. AGC MODIFICATION

The stock SRF-59 has an excellent automatic gain control (AGC). It is beneficial to utilize **fast-AGC** during band scanning and **slow-AGC** during listening. The AGC is slowed by addition of capacitance in parallel to the existing capacitor. The CXA1129N's three AGC pins can be traced: then capacitance added. The RF-amplifier **AGC1** is pin 3; the post-detector **AGC2** is pin 9; and a post-mixer **OL_AGC** is pin 25. Testing suggests that adding **200 uF** to pin 25 might be beneficial.

8. OPERATING THE MODIFIED SRF-59

To use the Hellenized SRF-59: apply power, set the volume, and set the band to AM. The stock headset may be replaced with earbuds. Tune the radio to a **vacant spot** within the band of interest. Slowly move the stock tuning wheel until the **hissing sound is maximized**. The antenna cannot be tuned while sitting on a station (this will simply elicit AGC action). Now tune the radio very slowly and listen for stations. The antenna tuning can be re-adjusted. Offset tuning (tuning to one side of a station) can be utilized to increase fidelity or help with selective fading distortion.

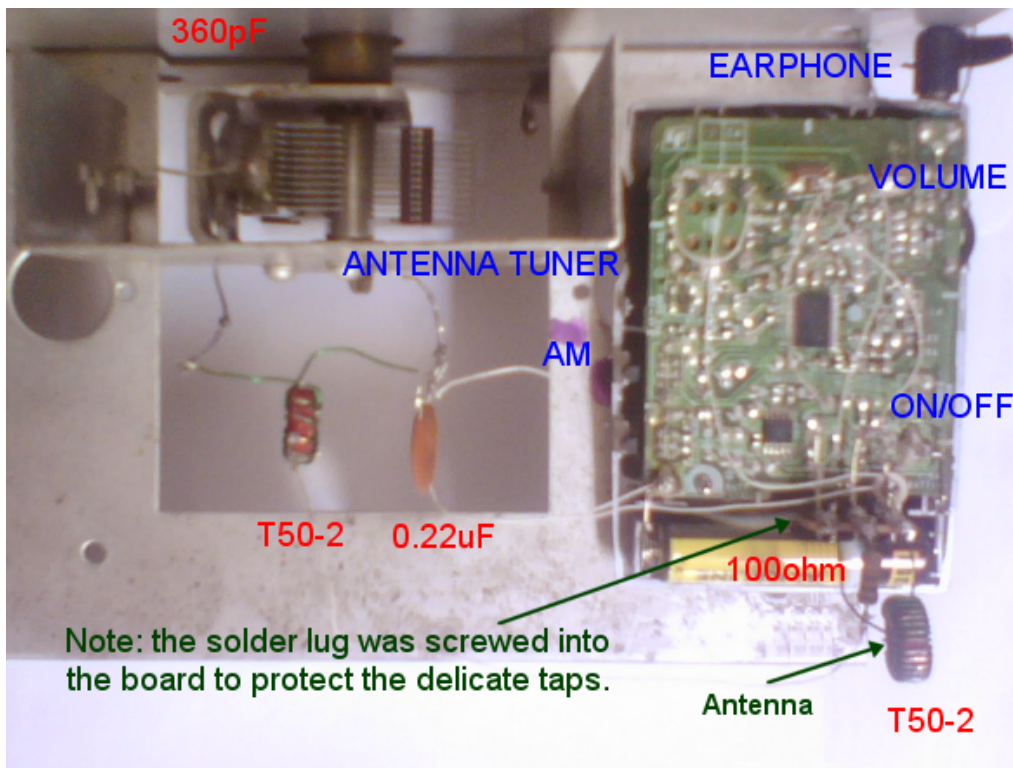
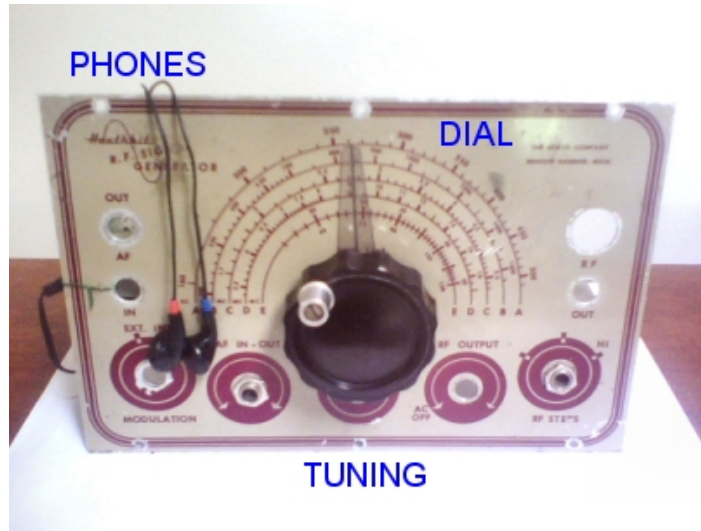

9. DISCUSSION

In **Phil's SW Radio Picks** I recommend some portables including the [KA2100](#). Although the Hellenized SRF-59 is not as sensitive it can essentially hear anything the KA2100 could. The modified SRF-59 makes a solid shortwave DXer. The radio shines during program listening: the 55-kHz filters have a unique sound, Sony's detector is first-rate, and [listening hour after hour is not tiring](#). There is also ample room for improvement of this base design by other radio hackers.



just_rtfm@<NOSPAM>yahoo.com
http://home.comcast.net/~phils_radio_designs

Copyright 2011
 Dr. Phil