

Phil's Fidelity Increase Mod Version 1.0 for the ICOM R75



WARNING: Performing this mod will void your warranty and could **destroy** your radio.
WARNING: DO NOT perform this mod without some type of **eye protection**.
CAUTION: This mod takes soldering skill so please practice beforehand.
DISCLAIMER: The author is not responsible for any damage resulting from this mod.

1. Abstract:

Increase audio fidelity by soldering a separate 47k-ohm resistor in parallel with resistors R1212, R1213, R1214, and R1215. This is a modification for audiophiles (i.e. program and music listeners) who wish to enhance the already excellent AM (SAM) sound gained from Dr. Rado's Sync-AM and AM-AGC mods.

2. Introduction:

The R75 block diagram shows that a 3 kHz low-pass filter exists between the audio-frequency select chip (IC1201) and the audio pre-amp. The audio bandwidth is purposely decreased to aid functioning of the optional UT-106 DSP. Unfortunately this attenuates the R75's high frequency audio response. Inspection of the schematics revealed that ICOM utilizes dual active two-pole low-pass filters. These two filters (enclosed in a green circle below) employ op-amps (yellow triangles below), specifically 1/4 of the NJM2058 Quad Operational Amplifier chip each.

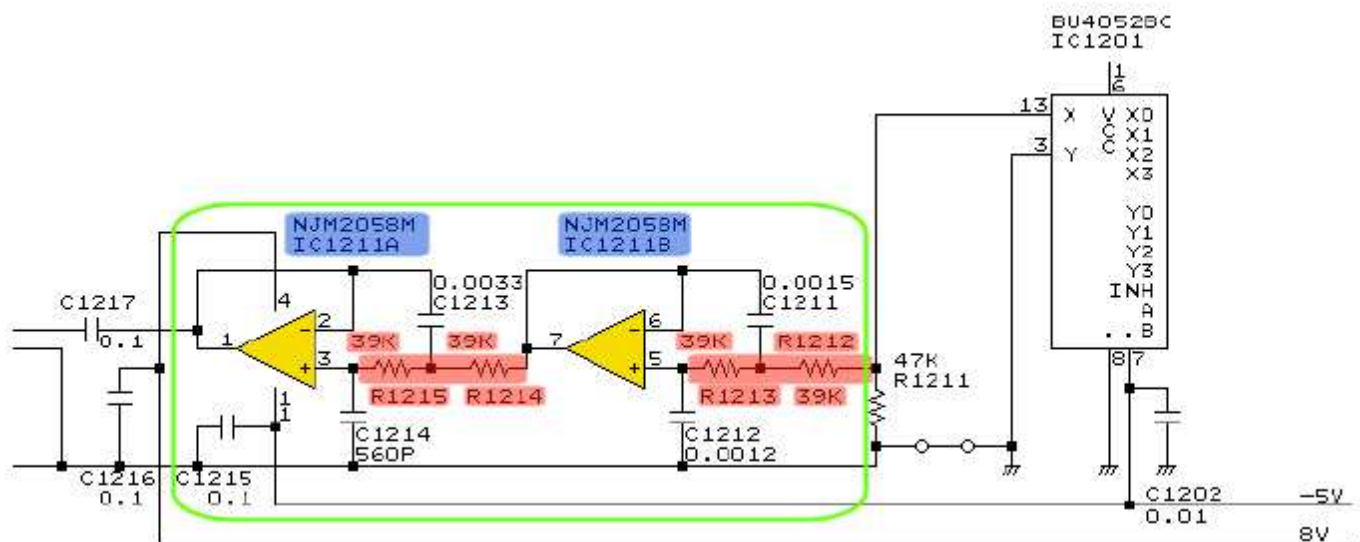

3. Theory:

The following equation was used for calculations: $4 * \pi^2 * f^2 * R1 * R2 * C1 * C2 = 1$. Where f is the cutoff frequency, $R1$ & $R2$ are resistance values, and $C1$ & $C2$ are capacitance values. I calculated the stock 1211A (left yellow op-amp above) filter as being set to 3001 Hz and the stock 1211B (right yellow op-amp above) filter as being set to 3041 Hz.

The R75's audio fidelity can be increased by soldering a resistor in parallel with each of the four 39k-ohm resistors (shown in red above) in the low-pass filters. Using some theoretical guidelines Ken experimentally determined the optimal value of the four parallel resistors to be 47k-ohms. Usage of these four 47k-ohm resistors in parallel with the stock 39k-ohm resistors yields 21.3k-ohms total effective resistance and will raise the bandwidth of the low-pass filters to 5493 Hz and 5566 Hz respectively. [Please note that as an alternative four 100k-ohm resistors in parallel (28k-ohms total effective resistance) will yield ~4200 Hz of bandwidth.]

It was originally theorized that the DSP used a 6000 Hz sample rate and that filtration was needed to eliminate signals above the Nyquist frequency to avoid aliasing distortions. However, these filters may have been added to avoid the noticeable loss of highs incurred by DSP usage. Engaging the DSP (with the NR or ANF button) returns the R75 to its unmodified sound.

Spectral analysis revealed an increase in frequency response from 3200 Hz in the stock unit to 4800 Hz in the modified unit. The result is unimpeded high fidelity sound from the R75. Music sounds fuller while using the 6 kHz filter and even more so using the pseudo dual-15 kHz filter setting. Usage of amplified external speakers with tone control is recommended.

4. Warnings and Preparation:

Please wear eye protection. Before you begin disconnect all cables ESPECIALLY the power supply and avoid static discharge by grounding yourself. Be careful that the soldering iron does not burn any cables!

5. Materials:

To perform this modification you will need the following items:

- four 47k-ohm resistors (Radio Shack sells a 5-pack for 99 cents)
- thin insulated wire (ex. wire wrap) and electrical tape (to insulate exposed wire)
- a low-wattage needle-tipped soldering iron, holder, sponge, and solder
- safety glasses or goggles

6. Methods:

- Take off the top cover by removing eight screws (see user manual for details).
- Locate the general region where NJM2058 op-amp (red square) is located from the picture below.



•Locate the four 39k-ohm resistors shown inside the red circles below. Using a magnifier you will note the resistors have the marking '393' that stands for 39k-ohms. You can check this via multimeter. Note the placement in relation to pins 3 and 5 of the NJM2058 op-amp. The green and purple markings correspond to the center and end connections, respectively (see schematics below). **CAUTION: Solder directly to the surface mount resistors and DO NOT allow solder to flow onto the adjacent NJM2058 pins** (see finished mod picture below).

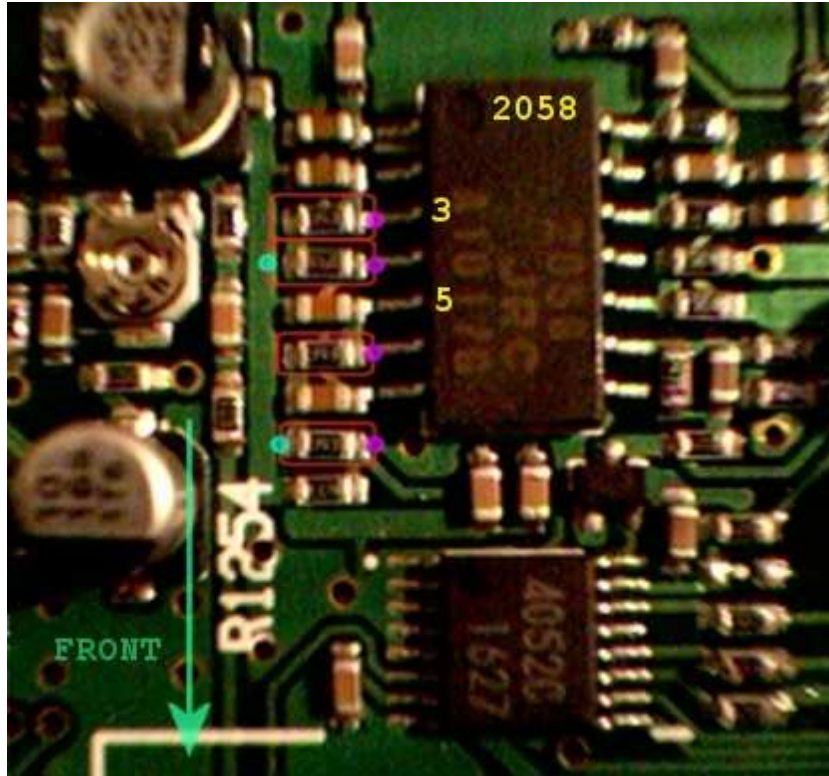

•These schematics show the six connections from the four 47k-ohm resistors (green below). Wires 2 & 5 make up the 'center' connections, whereas, wires 1 & 3 and 4 & 6 make up the 'end' pairs.

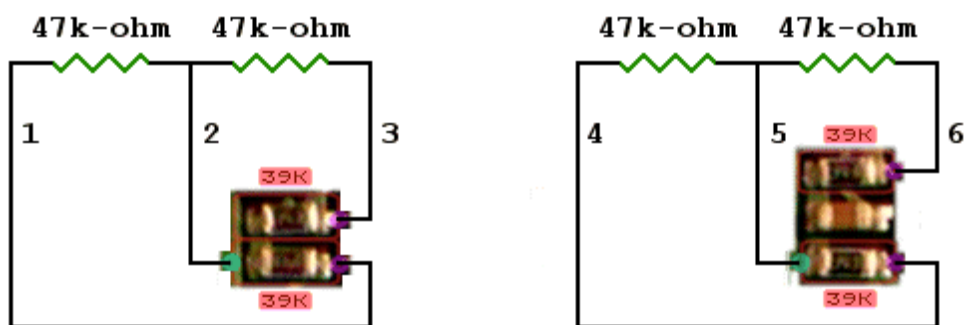

•The finished mod should look similar to the picture below. Note the color-coding used to easily identify the center (yellow & green) and end (blue pair & white pair) connections.

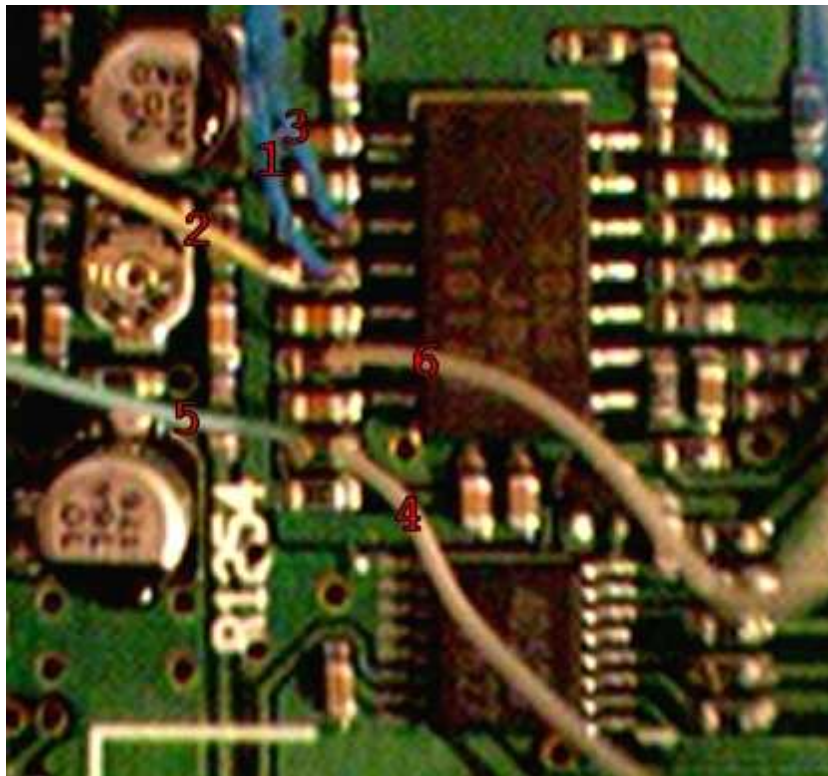

- Check visually that no short exists. **DO NOT leave any tools inside the unit!**
- Check everything again, close the unit back up and connect all cables.

7. Surface Mount Soldering Tips:

Please read the tips located in my ECSS Volume Mod PDF.

8. Conclusion:

Your R75 will now have significantly increased audio fidelity. ICOM created the R75 primarily as a SSB communications receiver. Dr. Rado's Sync-AM and AM-AGC mods transformed the R75 into a real performer on AM (SAM). This mod further enhances world-band program and music listening by increasing high frequency audio response. I can be reached at just_rtfm@yahoo.com with any comments. dr phil :)

9. Credits:

I wish to thank Ken for his determination, his knowledge, his skill, and most importantly his friendship... without his help there would be no mod.



'The Emperor is not as forgiving as I am.'

©2002 Phil

[EOF]