

Hacking the Si4734

Hellenized Si4734 Shortwave Receiver

VERSION 1 ©2010



This information is PRELIMINARY and may contain errors.

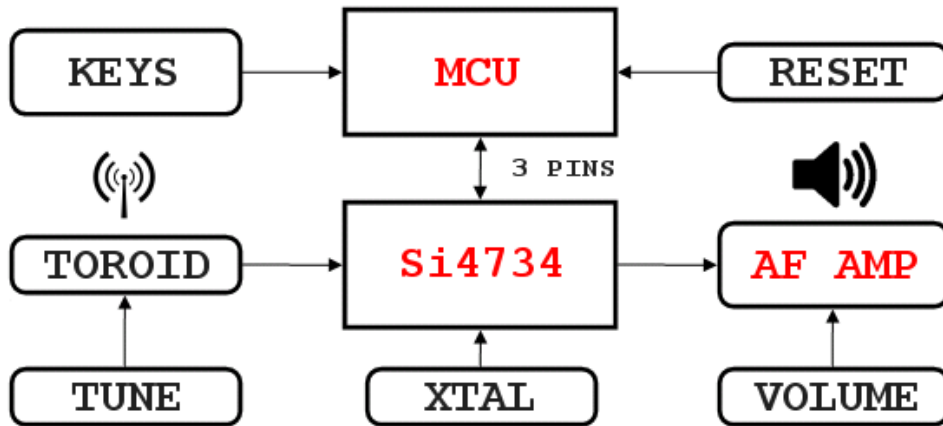

Above is a block diagram for a [Si4734-based](#) shortwave receiver. The goal was a no-frills shortwave DX machine. There is no display: punch in a frequency, select a filter, set the volume, peak the antenna, and listen. Hardware was broken into three sections: MCU, Si4734, and audio amplification. Software sections include: keypad polling, boot-up, plus bandwidth and frequency changing. **WARNING:** this is a preliminary design and may contain hardware or software errors.

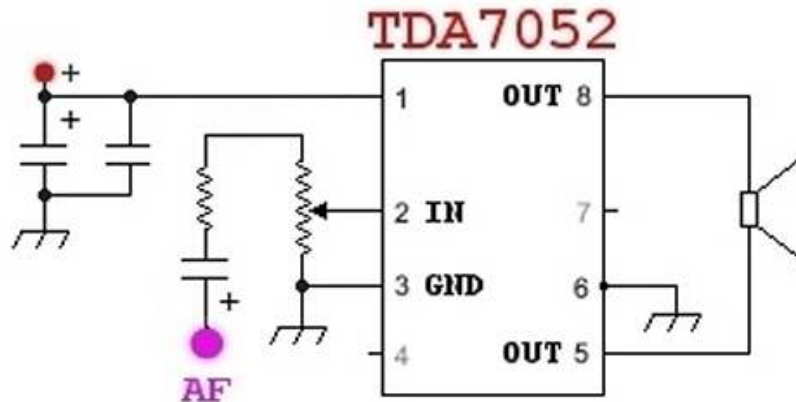

The [audio amplification](#) section consists of a [TDA7052](#) 1 Watt BTL (Bridge Tied Load) Mono Audio Amplifier. Pin 1 is power, decoupled thru two capacitors. Pin 6 is ground. Pins 5 and 8 drive an **8-ohm** speaker. Pin 2 accepts audio from the Si4734 through a potentiometer [volume control](#). Pin 3 is the input's ground. The TDA7052 is available as a PCB kit and is shown below on the [left](#).



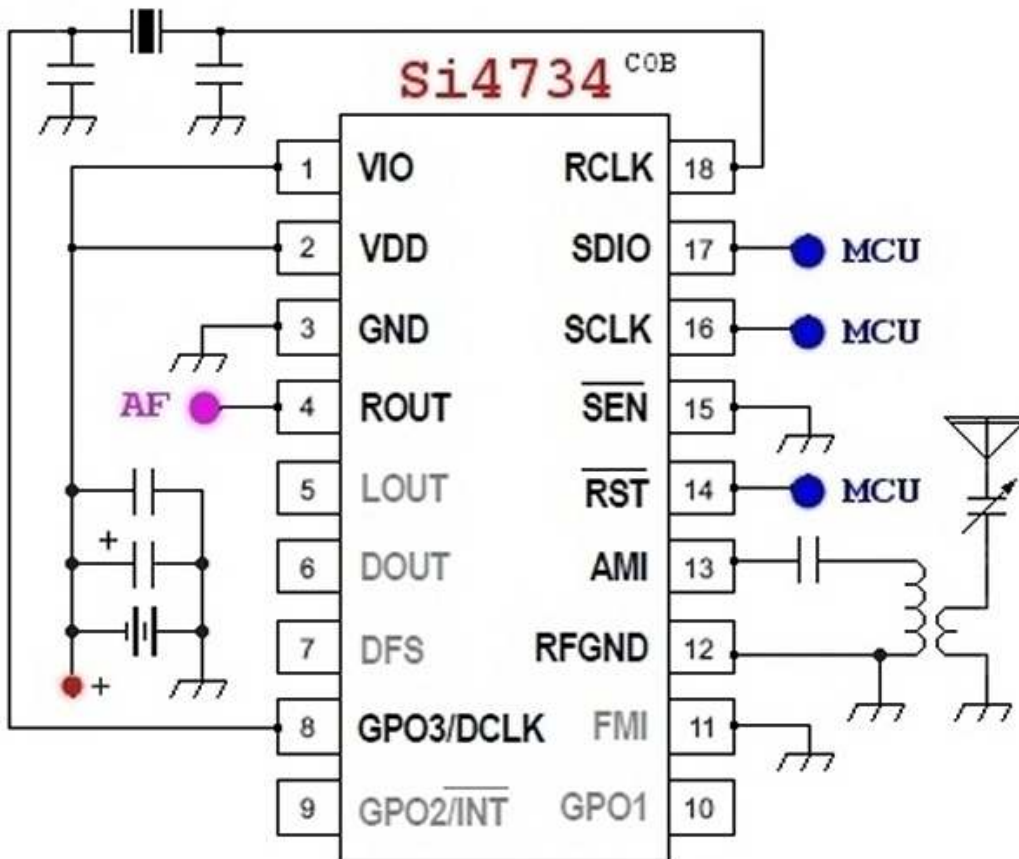

The heart of the radio is [Silicon Lab's Si4734](#) low-IF DSP receiver IC [on a COB assembly]. Power is derived via two "D" type batteries, decoupled by two capacitors. This is applied to Pins 1 (digital I/O voltage) and 2 (supply voltage). Pin 3 is ground. Pin 4, the right audio output, is sent to the TDA7052 chip for amplification. Pins 5, 6, and 7 (left output, digital lines) are unconnected. Pins 8 and 18 are connected via a [32.768 kHz crystal](#). Pins 9 and 10 (outputs) are not connected. Pin 11, the FM input, is grounded. Pins 12 and 13 form the AM input and are coupled via a toroid to an antenna with a trimmer capacitor. Pins 14, 16, and 17 are used for [MCU control](#): reset, I2C clock, and I2C data lines; respectively. Pin 15 is grounded, setting the I2C **bus address** to **0x22**.

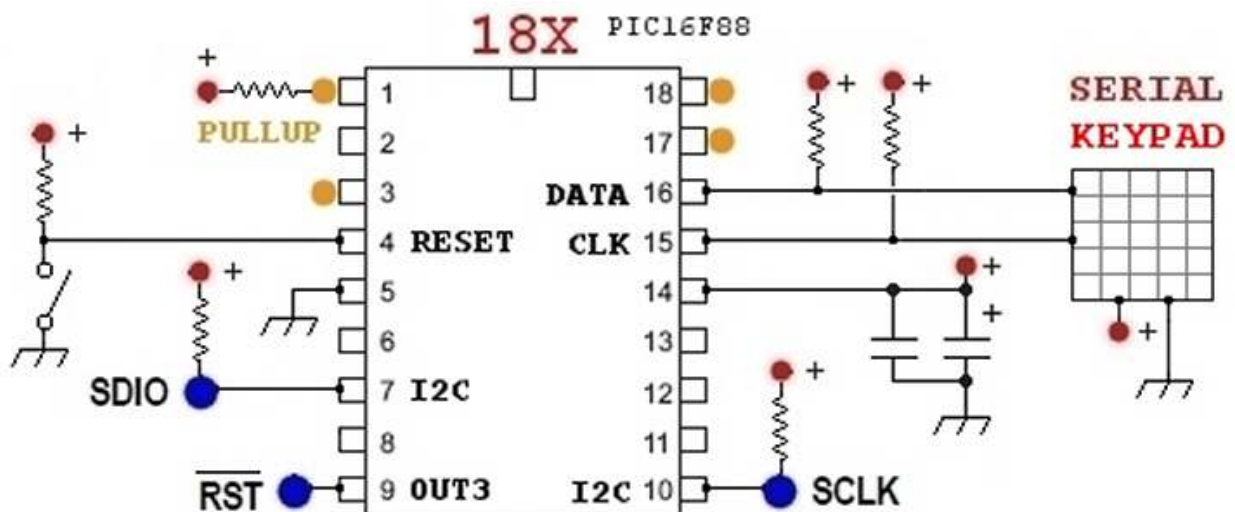

The [MCU](#) is a PICAXE [18X](#). Pin 14 is power, decoupled thru two capacitors. Pin 5 is ground. Pin 4 is a reset. Pins 7, 9, and 10 control the Si4734 IC via its I2C data, reset, and I2C clock lines. Pins 15 and 16 receive [serial keypad](#) data. Pins 1, 3, 17, and 18 (**and others**) use pull-up resistors. A substitute to a serial keypad, a **4 by 3** keypad, can be polled using a single **ADC** input (Pin 17).

The user interface is a keypad. Three commands are possible: **9 ENTER** reboots, **0 thru 8 ENTER** changes bandwidth, and typing a **3 to 5 digit number** then **ENTER** changes the frequency.

Software consists of a loop that polls keypad input and assembles a number. When **ENTER** is pushed, the program determines if the user requested a reboot, filter change, or tuning change.

```

MINIMALIST Si4734 SOFTWARE
main:           ; initialize variables
w0 = 0 | w1 = 0 | w2 = 100000           ; w2 is 10's place
polling:       ; keypad polling
KEYIN                                   ; get a key
w1 = -5                                 ; w1 holds digit
IF keyvalue = $45 THEN w1 = 0           ; check for 0 to 9
IF keyvalue = $16 THEN w1 = 1
IF keyvalue = $1E THEN w1 = 2
IF keyvalue = $26 THEN w1 = 3
IF keyvalue = $25 THEN w1 = 4
IF keyvalue = $2E THEN w1 = 5
IF keyvalue = $36 THEN w1 = 6
IF keyvalue = $3D THEN w1 = 7
IF keyvalue = $3E THEN w1 = 8
IF keyvalue = $46 THEN w1 = 9
IF keyvalue = $5A THEN enter           ; check for ENTER
IF w1 = -5 THEN polling                 ; is key invalid?
w2 = w2 / 10                             ; next 10's place
w0 = w1 * w2 + w0                         ; add digit to w0
GOTO polling
enter:         ; interpret command
IF w2 = 0 THEN main                       ; divide by zero?
w0 = w0 / w2                               ; fix 10's place
IF w0 = 9 THEN boot                         ; boot
IF w0 >= 0 and w0 < 9 THEN filter           ; filter
IF w0 >= 149 and w0 < 23001 THEN tune      ; tune
GOTO main

boot:          ; initialize Si4734
LOW 3 | PAUSE 250 | HIGH 3 | PAUSE 250    ; hard reset
I2CSLAVE $22,i2cfast,i2cbyte             ; setup I2C
WRITEI2C $22,($01,$11,$05)                ; POWER_UP
WRITEI2C $22,($80,$0E)                    ; GPIO_CTL
WRITEI2C $22,($81,$00)                    ; GPIO_SET
WRITEI2C $22,($12,$00,$33,$02,$00,$00)    ; SOFT_MUTE_OFF
GOTO main

filter:       ; bandwidth change
WRITEI2C $22,($12,$00,$31,$02,$00, b0)    ; AM_CH_FILTER
GOTO main

tune:         ; frequency change
WRITEI2C $22,($40,$00, b1, b0,$00,$00)    ; AM_TUNE_FREQ
GOTO main

```

REFERENCE

just_rtfm@<NOSPAM>yahoo.com
http://home.comcast.net/~phils_radio_designs

Copyright 2010
 Dr. Phil