

E**ELECTRIC COUNTER
TILTING KETTLE**

JOB NAME: _____

ITEM NO.: _____

NO. REQUIRED: _____

MODEL <input type="checkbox"/>	CAP <input type="checkbox"/>	ACITY <input type="checkbox"/>
<input type="checkbox"/> FT-20CE <input type="checkbox"/>	<input type="checkbox"/>	<input type="checkbox"/> 20 Gallons (76 Liters)

SIZE: 30 3/4" Wide x 24" Front-to-Back
 (781mm Wide x 610mm Front-to-Back)

SPECIFICATIONS:

Shall be a Market Forge Model FT-20CE self-contained, Electric Counter Tilting Kettle. A double wall kettle interior shall form a steam jacket around the lower 2/3 of the kettle. The jacket enclosure shall contain water and anti-freeze which is factory sealed. The bottom of the kettle shall be of hemispherical design for superior heat circulation.

The mounting base shall include 4 stainless steel tubular legs fitted with a 4 hole adjustable foot for securing the unit to the floor and a stainless steel clad mechanism housing.

A removable operating handle with heat proof knob shall be mounted on the right.

Construction shall be all welded satin finish, stainless steel, type 304.

The controls shall be integrally mounted and shall include a power switch, thermostat, pilot light, vacuum/pressure gauge, safety valve, low water light, and low water shut off.

The kettle shall operate in a temperature range of 100°F to 290°F (38°C to 144°C) at a maximum pressure of 50 psi (3.4 kg/cm²). All kettles shall be standard with removable elements.



Floor Model FT-20CE Shown

OPERATION SHALL BE BY:

Electrically Self-Contained closed Steam System equipped for operation on:

- 208 VAC, 1 or 3 Phase, 50/60 Hz.
- 230 VAC, 1 or 3 Phase, 50/60 Hz.
- 240 VAC, 1 or 3 Phase, 50/60 Hz.

OPTIONAL AT EXTRA COST:

- One piece Lift-Off stainless steel cover.
- Stainless Steel wire basket.
- 1 1/2" (38mm) Draw-Off valve.
- Strainer for Draw-Off valve.
- Double pantry faucet with swing spout.
- Single pantry faucet with swing spout.
- Mixer modes (Consult Factory).
- 220/380, 240/415 VAC, 3 Phase, 4 wire.
- 380, 415 or 480 VAC, 3 Phase 50/60 Hz.
- Strainer Hook.
- Graduated Measuring Stick.

The manufacturer reserves the right to modify materials and specifications without notice

Spec No. S-4054
09/03

FOOD SERVICE EQUIPMENT
Counter Tilting Kettle



Printed in U.S.A.



MARKET FORGE
INDUSTRIES INC.

An Employee Owned Company

35 Garvey Street • Everett • MA • 02149
 Tel: (617) 387-4100 • Fax: 1-800-227-2659 (Ex. MA) • (617) 387-4456 (MA and Overseas)
 E-Mail: CUSTSERV@mfi.com • Website: www.mfi.com

E**ELECTRIC COUNTER
TILTING KETTLE****DETAILS & DIMENSION****SERVICE CONNECTIONS**

EC Electrical Connection -To be as specified on data plate.

ELECTRICAL CHARACTERISTICS

MODEL	PH	208V		230V		240V		380V		415V		480V	
		KW	AMP	KW	AMP	KW	AMP	KW	AMP	KW	AMP	KW	AMP
FT-20CE	3	12	33.4	12	30.1	12	28.9	12	18.3	12	16.7	12	14.5
	1	12	57.6	12	52.2	15	50.0	---	---	---	---	---	---

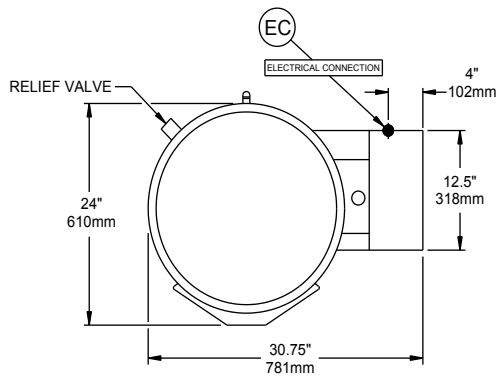

4 EQUALLY SPACED
7/16" 11mm DIA. HOLES
ON 3" 76mm B.C.
FLANGED FOOT DETAIL

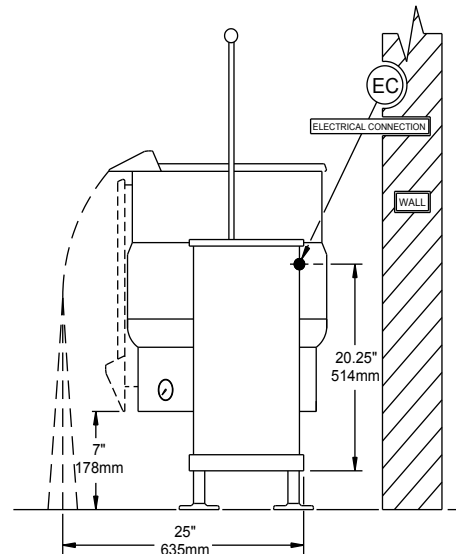
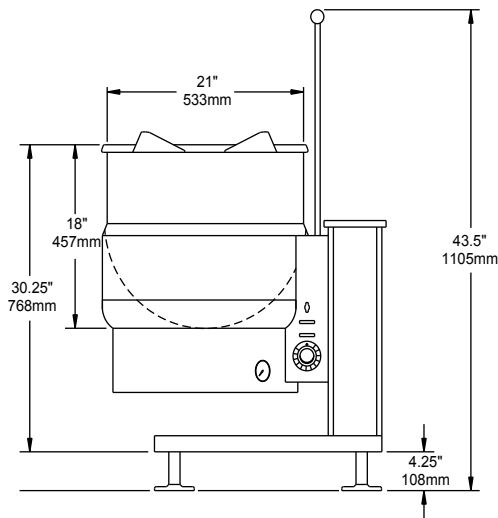

*It is our policy to build equipment which is design certified by U.L., A.S.M.E., N.S.F. and C.S.A. However, a continuing program of product improvement makes it necessary to submit new models to the agencies as they are developed and consequently not all models bear the appropriate agency labels at all times.

Spec No. S-4054
09/03

FOOD SERVICE EQUIPMENT
Counter Tilting Kettle



MARKET FORGE
INDUSTRIES INC.

An Employee Owned Company



Printed in U.S.A.

35 Garvey Street • Everett • MA • 02149
Tel: (617) 387-4100 • Fax: 1-800-227-2659 (Ex. MA) • (617) 387-4456 (MA and Overseas)
E-Mail: CUSTSERV@mfii.com • Website: www.mfii.com